

PAGE CONTENT

1. COVER PAGE
2. SYSTEM BLOCK DIAGRAM
3. Power Block Diagram
4. Power on Sequence
5. CPU_DDR0
6. CPU_DISPLAY
7. CPU_SATA/PCIE
8. CPU_PMU/CLOCKS
9. CPU_USB
10. CPU_DDR1/SOC_POWER1
11. CPU_SOC_POWER2
12. CPU_GND
13. DDR3_SODIMM
14. EDP TO LVDS
15. USB HUB_GL850G
16. LAN-RTL8111E/8105E-VL-CG
17. TPM/G-SENSOR/LS
18. SATA/EMMC/CARD READER
19. EC IT8528E
20. LVDS Con.
21. HDMI Con.
22. 3G Con.
23. WIRELESS Con.
24. BT/IO/TS/Quick Con.
25. USB3.0/TP/Buttom
26. LEVEL SHIFT (EC)
27. LEVEL SHIFT (SOC)
28. DC-IN/ BATT-IN/ Charger
29. +V3P3A / +V5A (OZ8153)
30. CPU_CORE/VCC_GFX
31. 1.5S/1.05S/1.8A/0.675S/Solar
32. +V1P35 /+V1P0
33. POWER SWITCH
34. Audio Codec (ALC283)
35. USB/LED/POWER SW

PCB1
EF10M12 M/B REV:01, P/N: 15BFU9-011000

PCB2
EF10M12 IO/B REV:01, P/N: 15BFU9-051000

System Power On/Off Sequence

Power On Timing

Power Off Timing

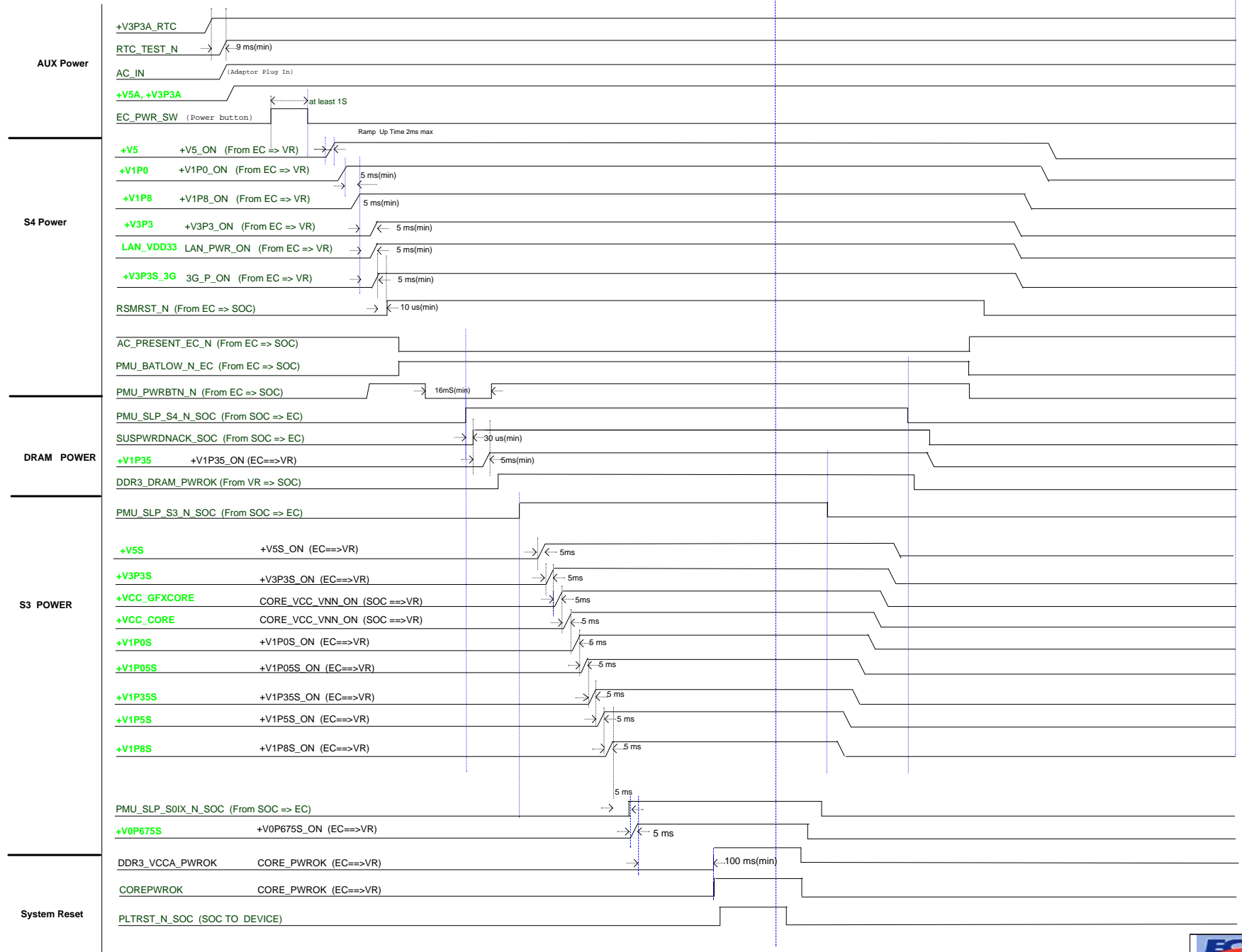

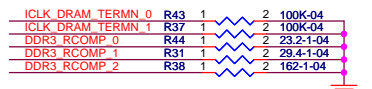
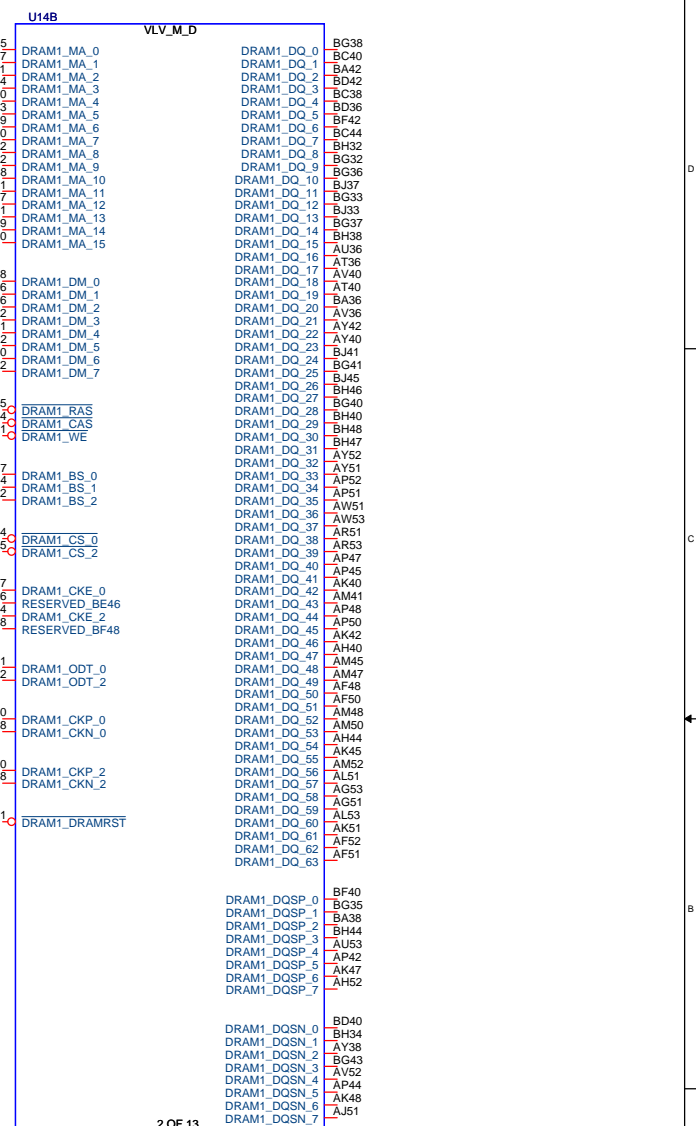
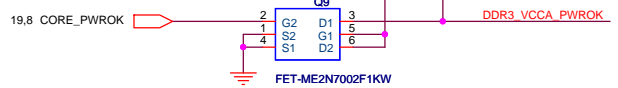
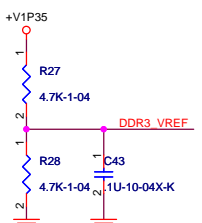
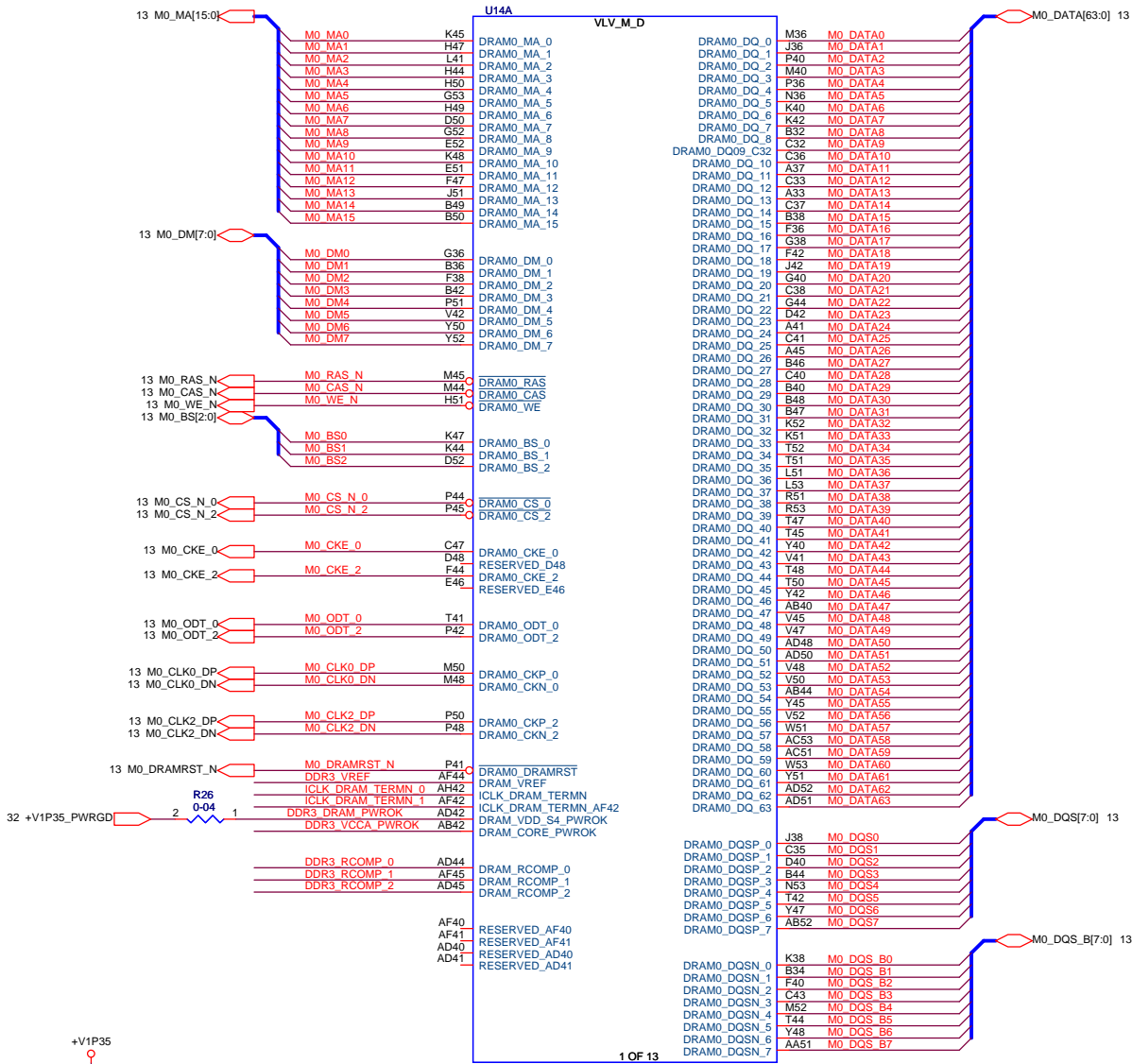

ELITEGROUP

Project : EF10MIX

Size	Document Number	Rev
	CPU_DDR0	01

Date: Monday, December 16, 2013 Sheet 5 of 35

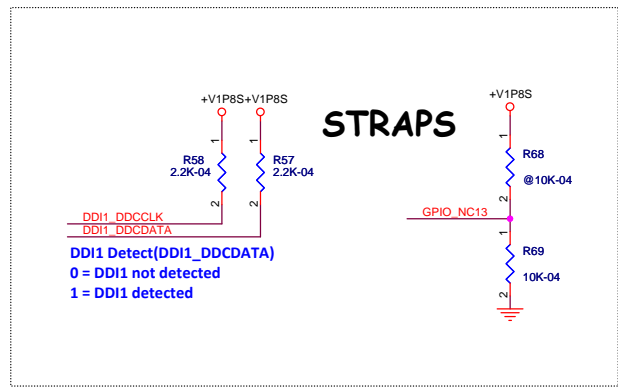
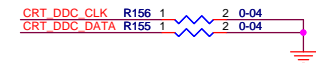
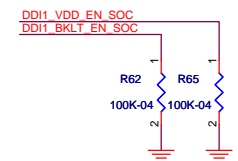
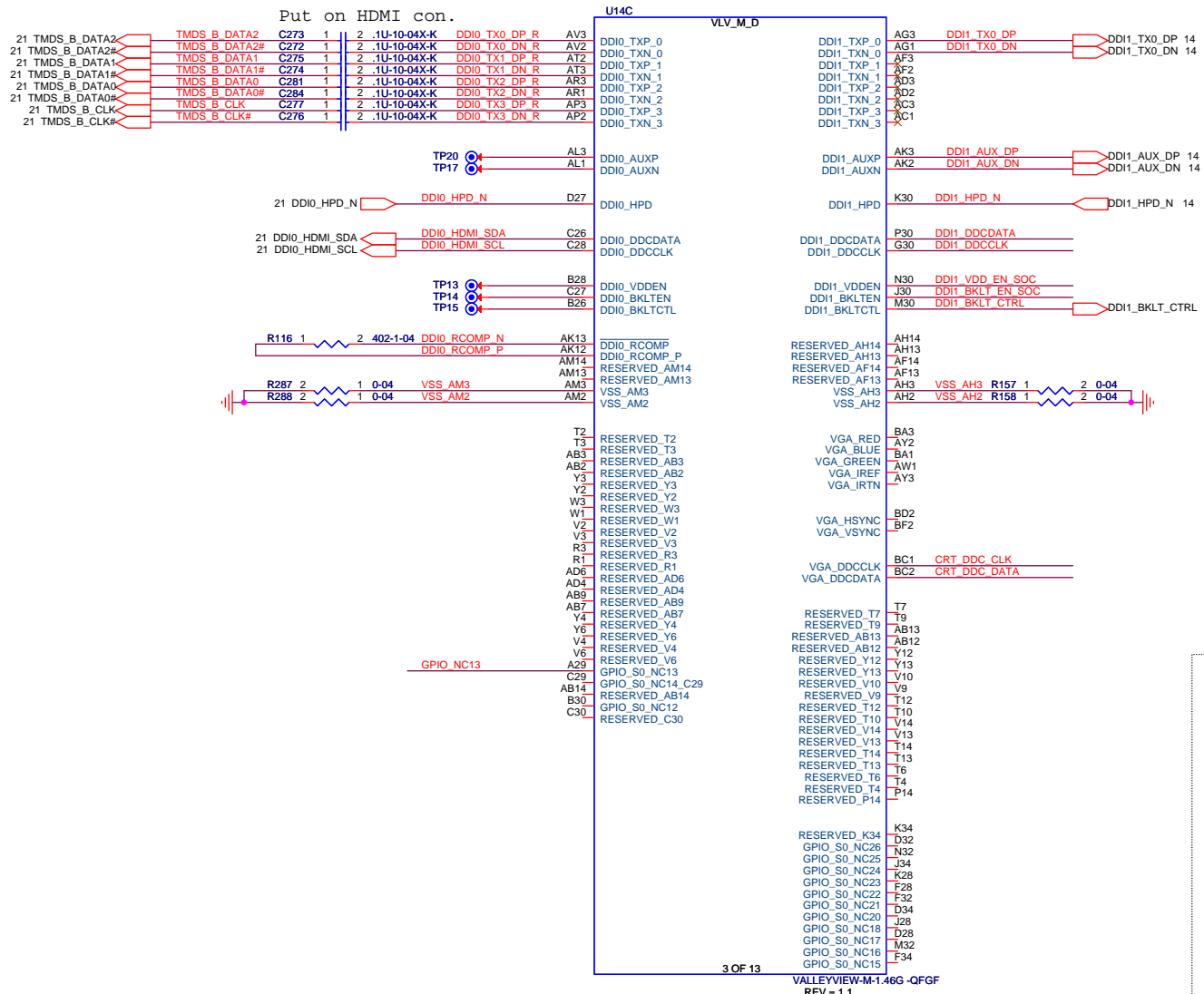

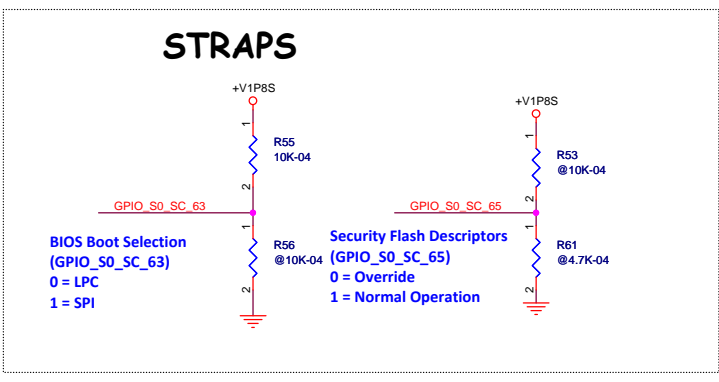
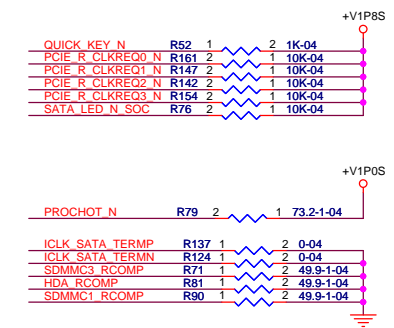
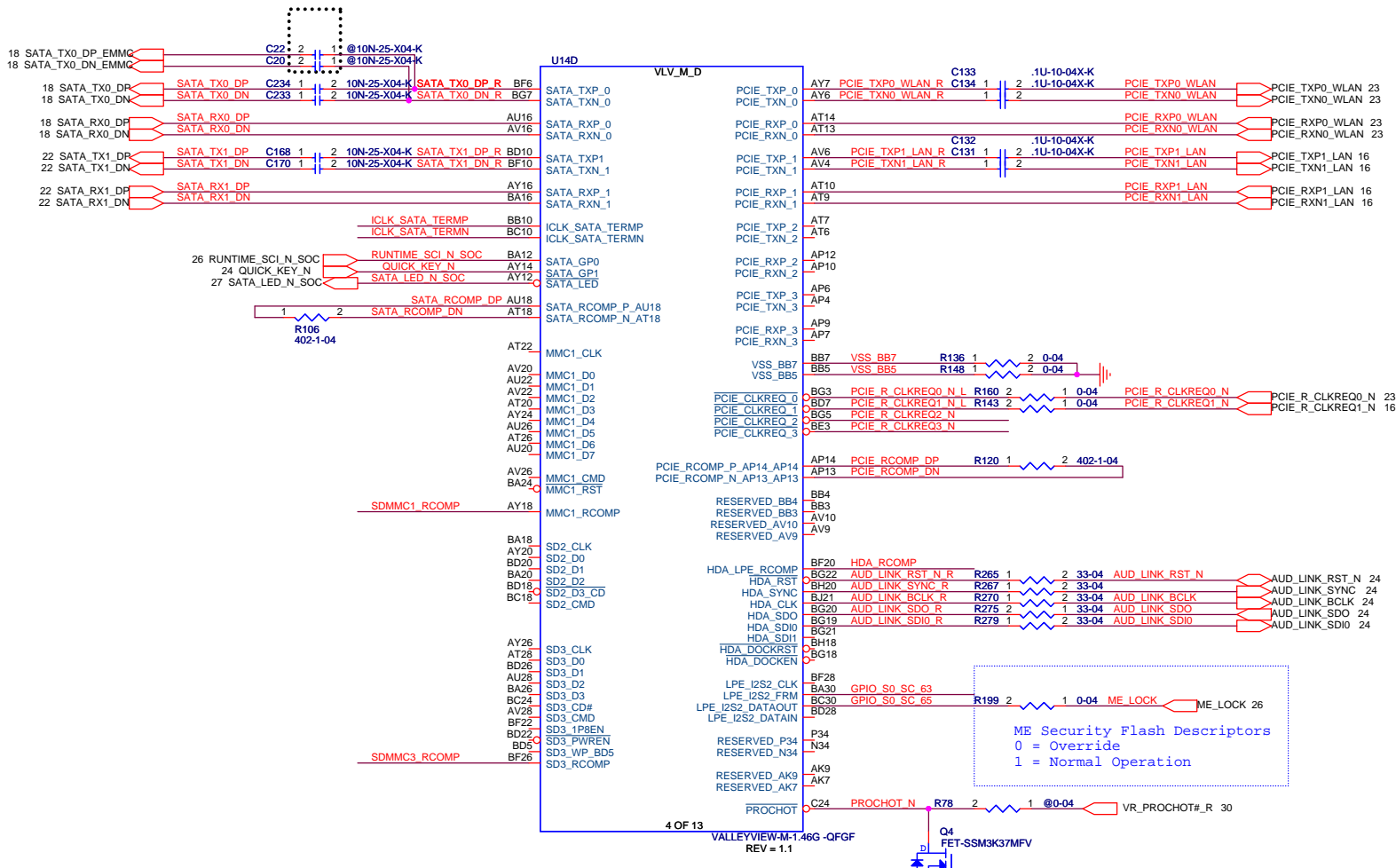

ME Security Flash Descriptors

- 0 = Override
- 1 = Normal Operation

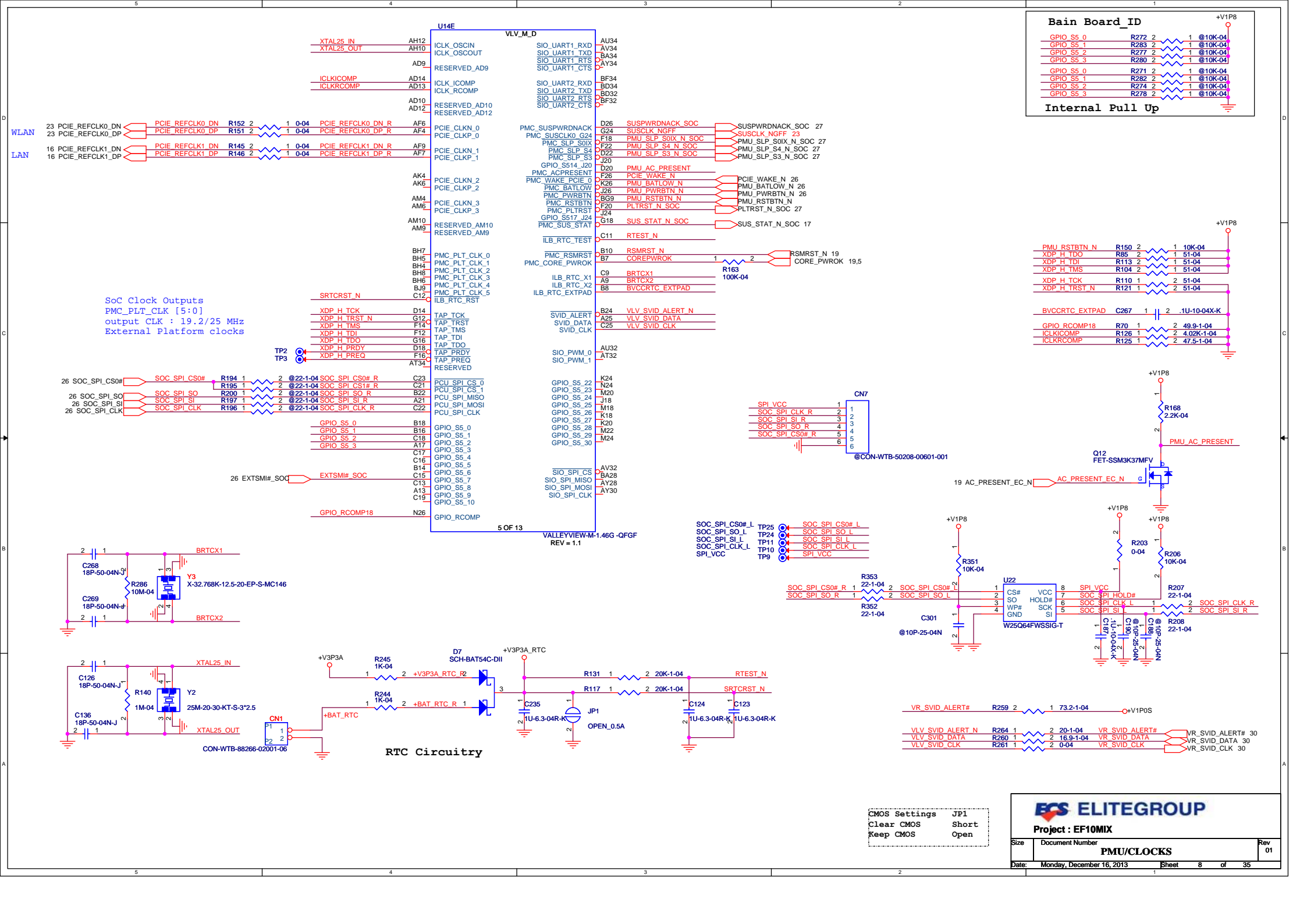

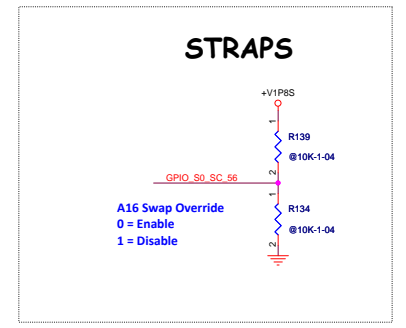
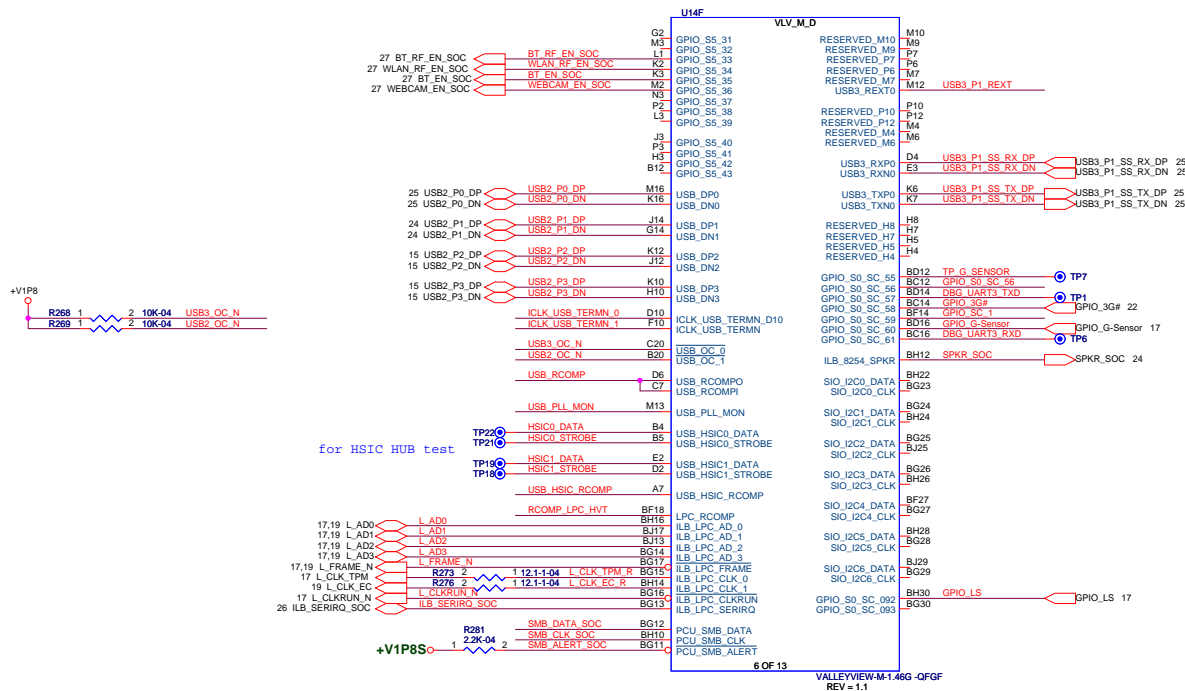

Device ID----

Device ID	GPIO_3G#
W/3G	HIGH
W/DTV	Low

Device ID----

Device ID	GPIO_LS
W/LS	HIGH
W/O LS	Low

Device ID----

Device ID	GPIO_G-Sensor
W/G-Sensor	HIGH
W/O G-Sensor	Low

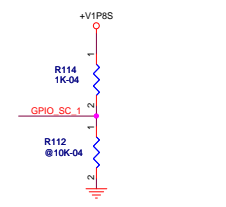
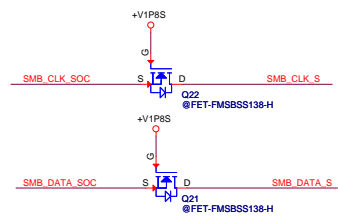
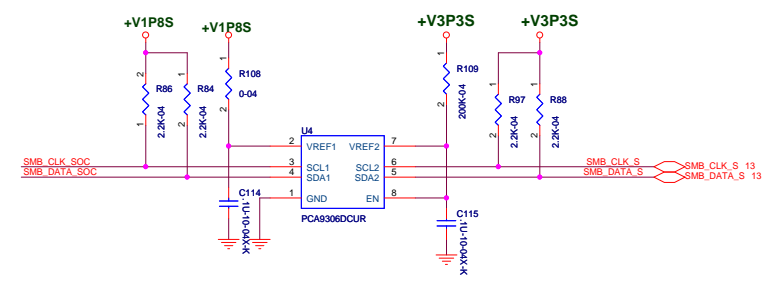
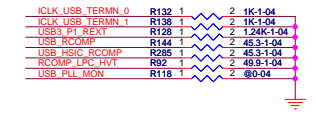

USB 2.0	Port 0	Port 1	Port 2	Port 3	HUB 1.1	HUB 1.2	HUB 1.3	HUB 1.4
DEVICE	USB 3.0 / 2.0 port	USB 2.0 Port	USB HUB 1	USB 2.0 Port	COMBO BT	Touch/S	WEBCAM	Card Reader
USB 2.0	0	1	2	3	HUB 1.1	HUB 1.2	HUB 1.3	HUB 1.4
DEVICE	USB 3.0 / 2.0 port	USB 2.0 Port	USB HUB 1	USB HUB 2	DTV / 3G	USB 2.0 Port	SIM Card	Sensor HUB

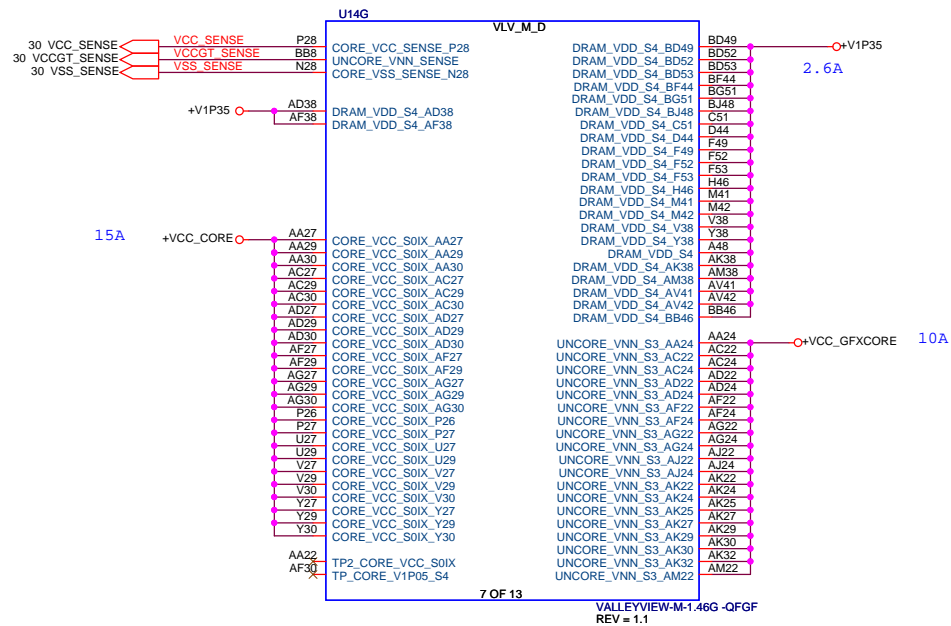

+VCC_GFXCORE

C77	1	2	.1U-10-04X-K
C101	1	2	.1U-10-04X-K
C100	1	2	1U-6.3-04R-K
C99	1	2	1U-6.3-04R-K
C90	1	2	1U-6.3-04R-K
C129	1	2	10U-6.3V-06R
C127	1	2	10U-6.3V-06R
C128	1	2	10U-6.3V-06R
C263	1	2	@22U-6.3-08R
C262	1	2	@22U-6.3-08R

+V1P35

C53	1	2	.1U-10-04X-K
C58	1	2	.1U-10-04X-K
C45	1	2	.1U-10-04X-K
C51	1	2	.1U-10-04X-K
C57	1	2	.1U-10-04X-K
C62	1	2	1U-6.3-04R-K
C54	1	2	2.2U-6.3-06R-K
C50	1	2	2.2U-6.3-06R-K
C64	1	2	2.2U-6.3-06R-K
C59	1	2	2.2U-6.3-06R-K

+VCC_CORE

C256	1	2	22U-6.3-08R
C255	1	2	22U-6.3-08R
C254	1	2	22U-6.3-08R
C70	1	2	10U-6.3V-06R
C80	1	2	4.7U-6.3V-04R-M
C86	1	2	4.7U-6.3V-04R-M
C92	1	2	2.2U-6.3-04R
C81	1	2	2.2U-6.3-04R

ELITEGROUP

Project : EF10MIX

Size	Document Number	Rev
	CPU_DDR1/SOC_POWER1	01
Date:	Monday, December 16, 2013	Sheet 10 of 35

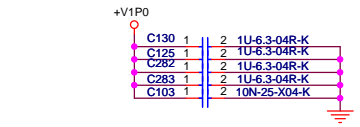
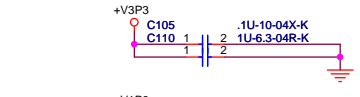
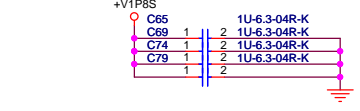
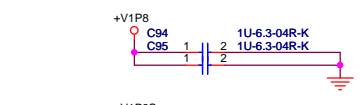
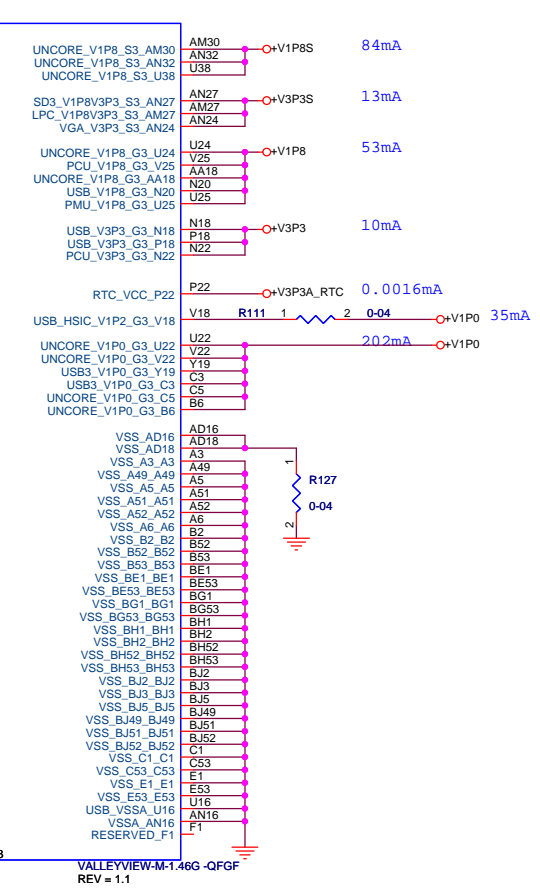
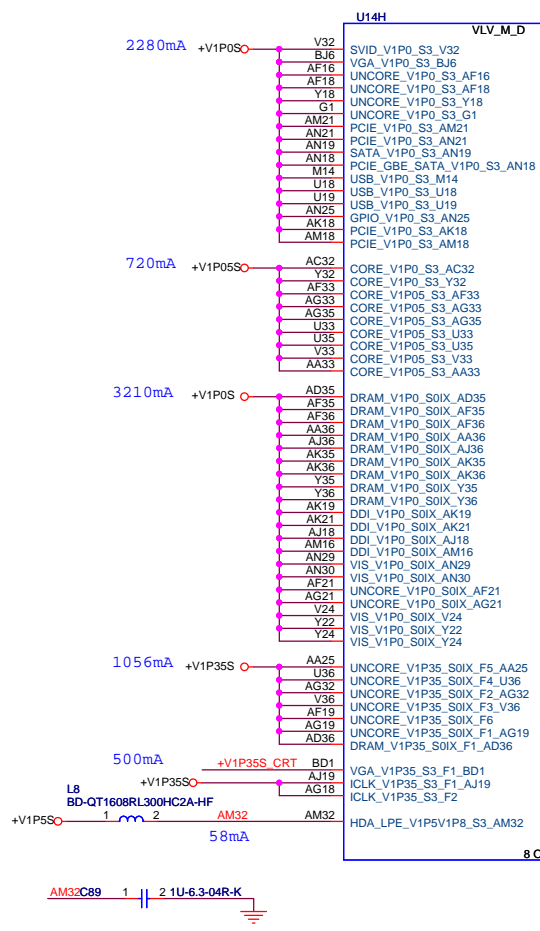
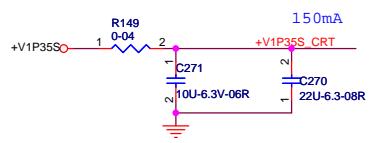
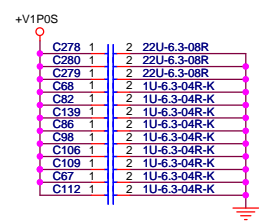
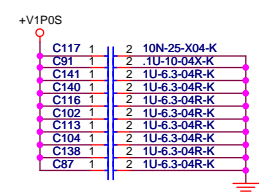
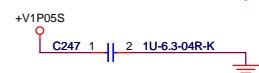
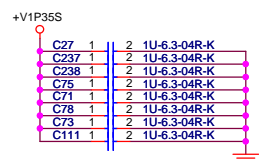
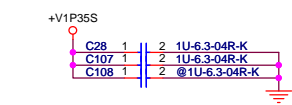

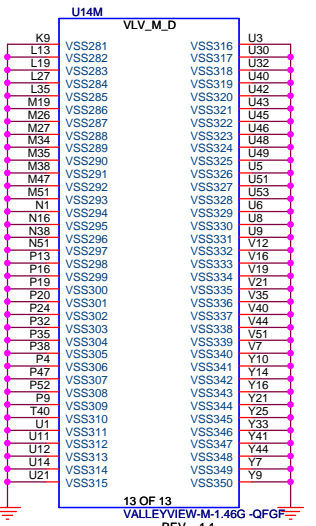
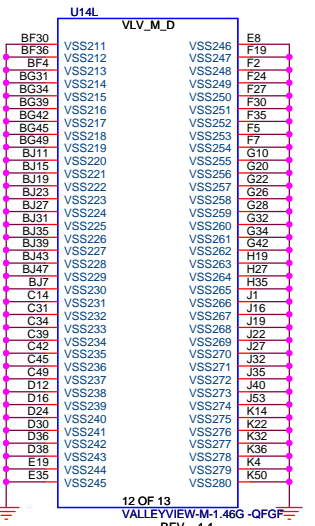
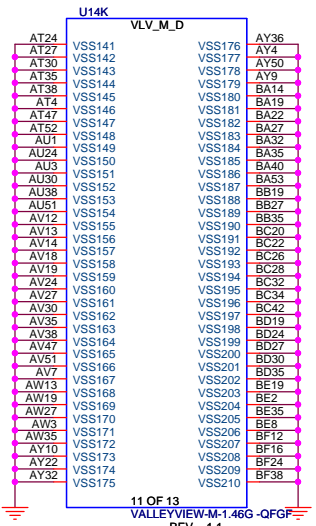
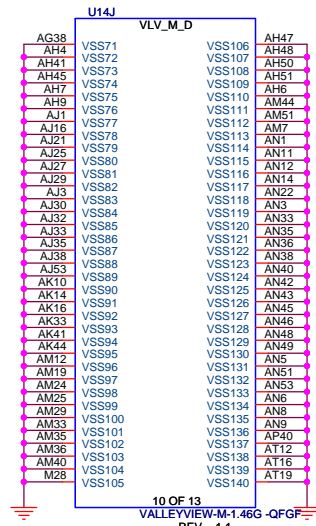
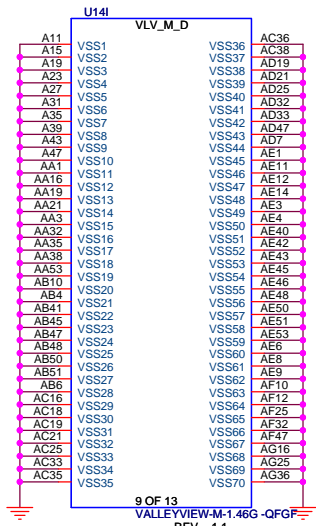

ELITEGROUP

Project : EF10MIX

Size	Document Number	Rev
	CPU_GND	01
Date:	Monday, December 16, 2013	Sheet 12 of 35

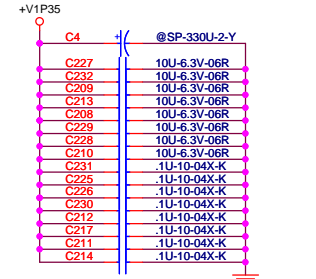
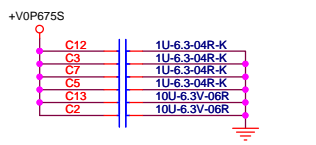
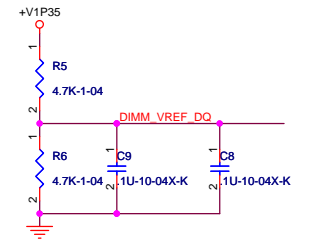
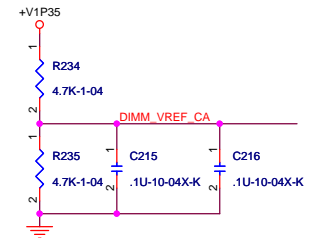
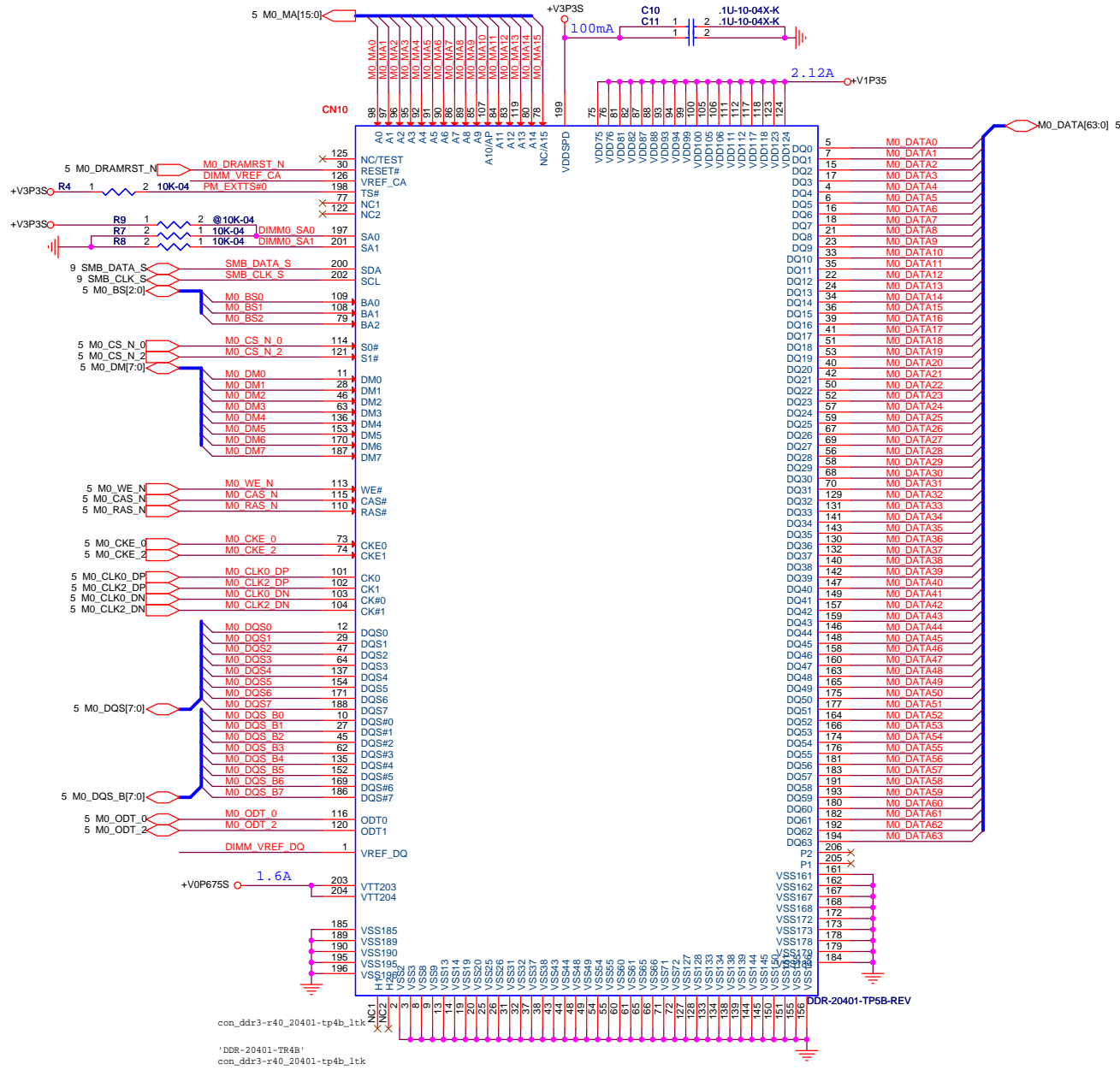

eDP to LVDS

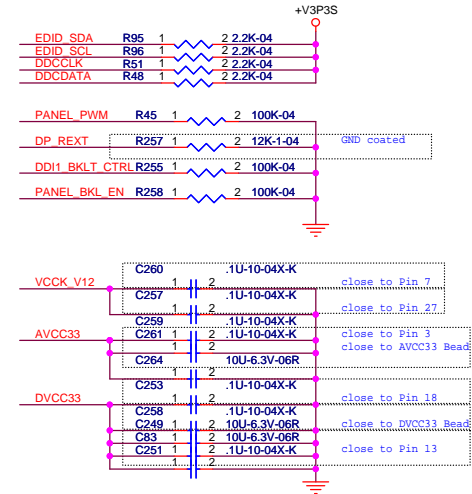
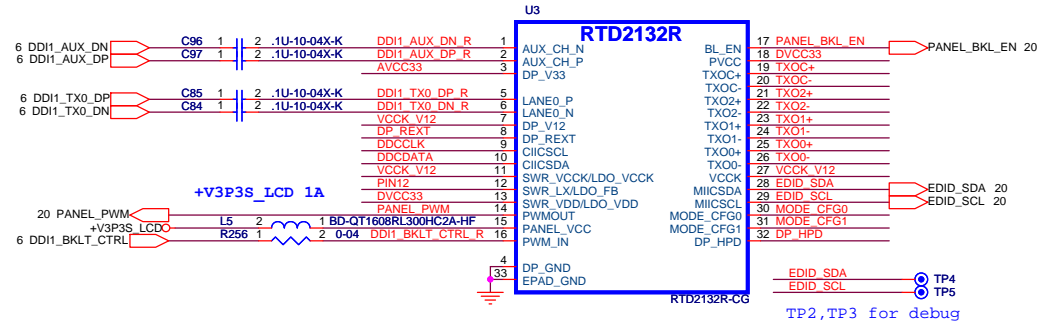
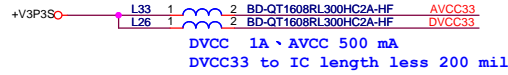

reserved slave address
0x94, 0x96, 0x6A

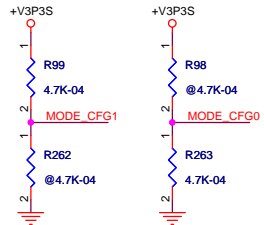

eDP / LVDS Select

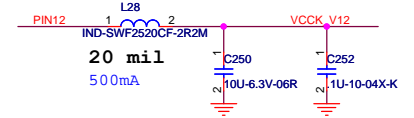
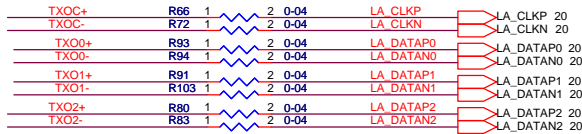

		MODE_CFG0(PIN30)	
		0	1
MODE_CFG1 (PIN31)	0	X	EP MODE
	1	ROM ONLY MODE	EEPROM MODE

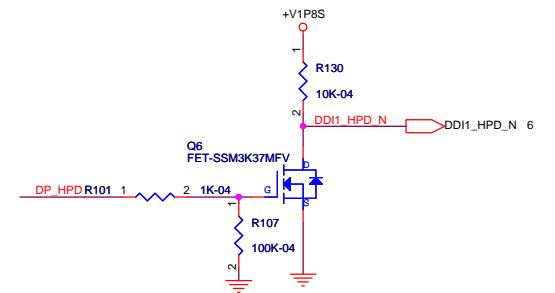

ELITEGROUP

Project : EF10MIX

USB HUB 1

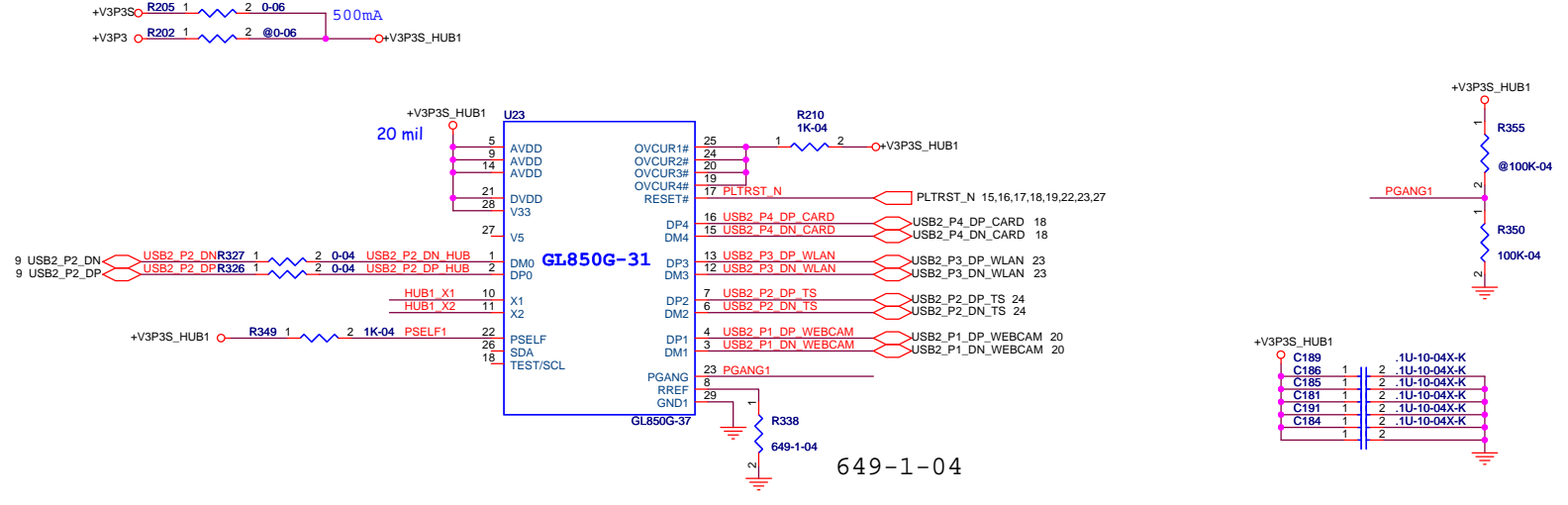

USB HUB 2

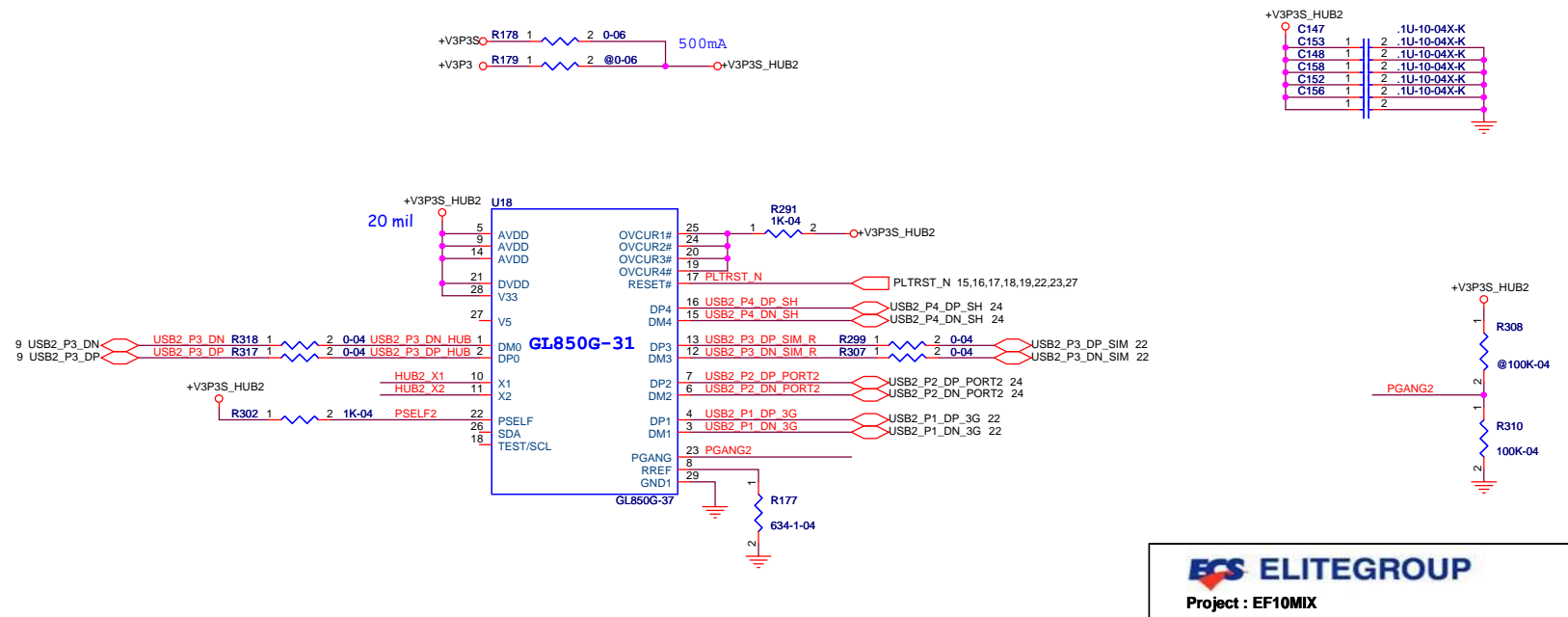

ELITEGROUP

Project : EF10MIX

Size	Document Number	Rev
	USB HUB	01
Date:	Monday, December 16, 2013	Sheet 15 of 35

LAN

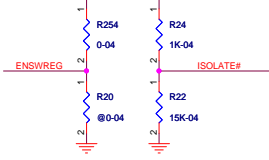
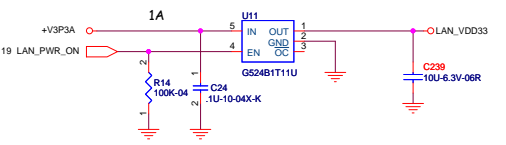
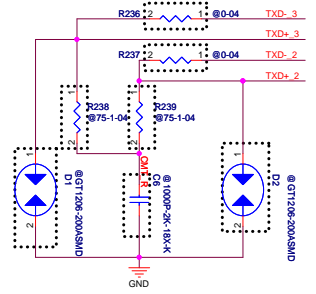
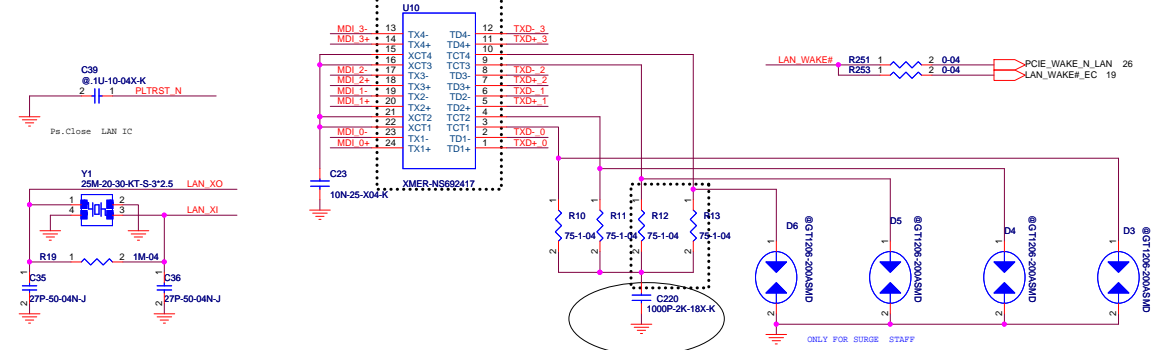
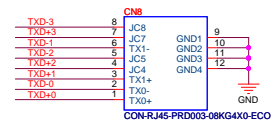
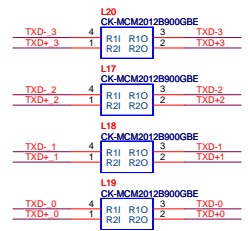
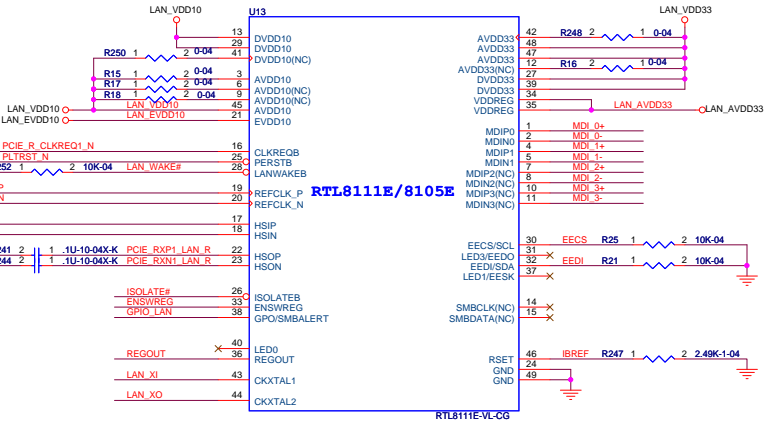
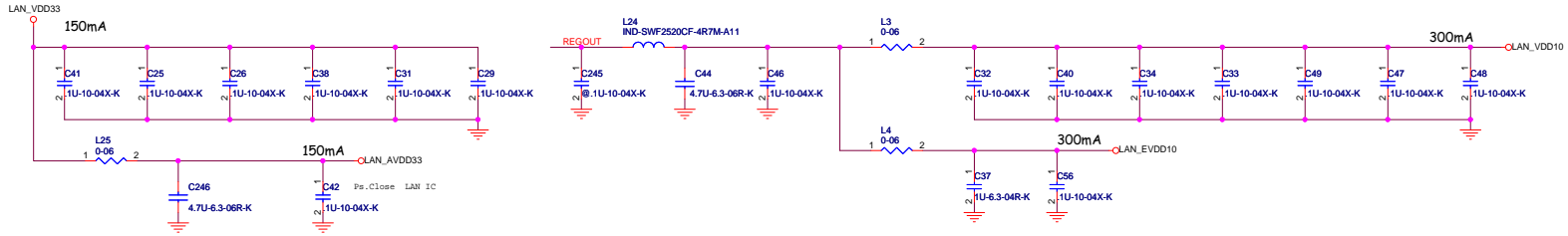

TPM

	WPCT201	NPCT620
R203	X	✓
R204	X	✓

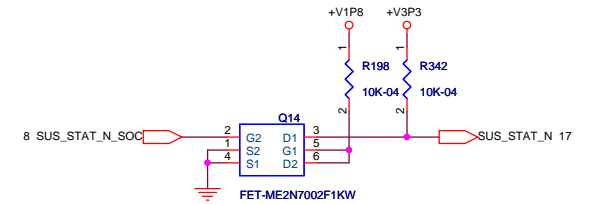
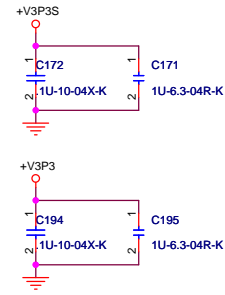
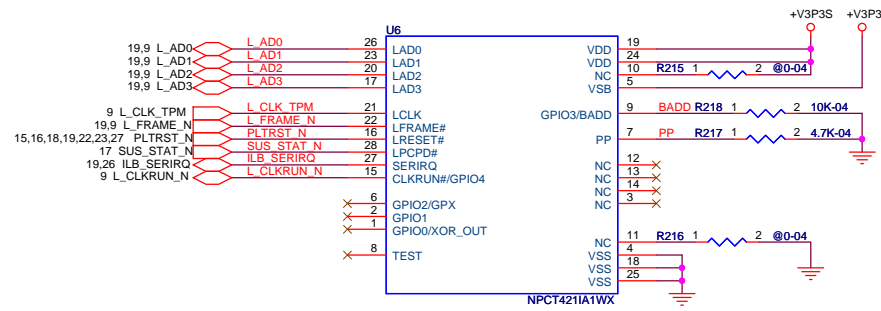

G-Sensor

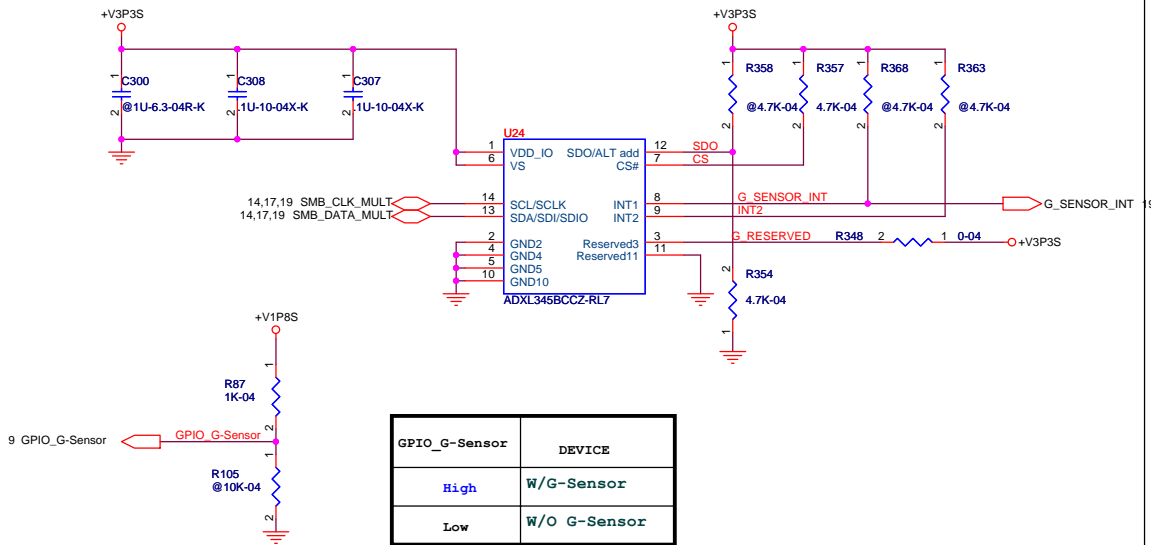

Light-Sensor

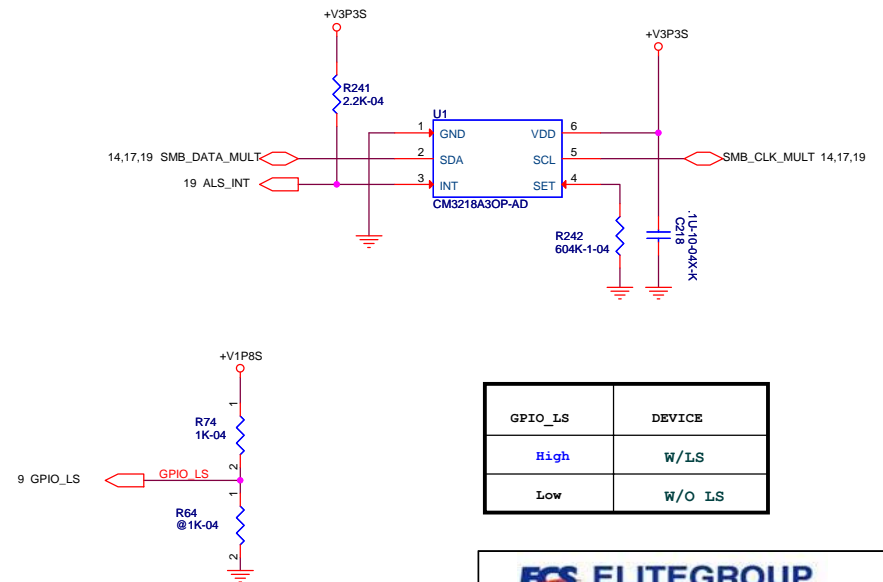

ELITEGROUP

Project : EF10MIX

Size	Document Number	Rev
	TPM/G-SENSOR/LS	01

Date: Monday, December 16, 2013 Sheet 17 of 35

CARD READER

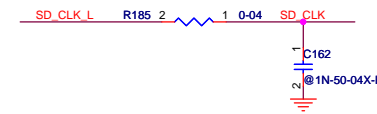
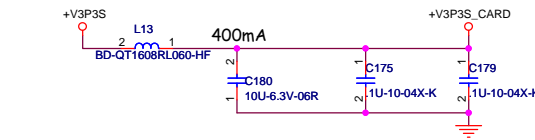
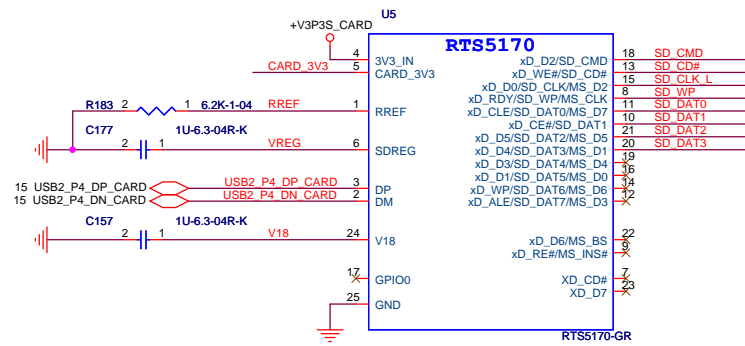

1. SD/MMC Card: 400mA

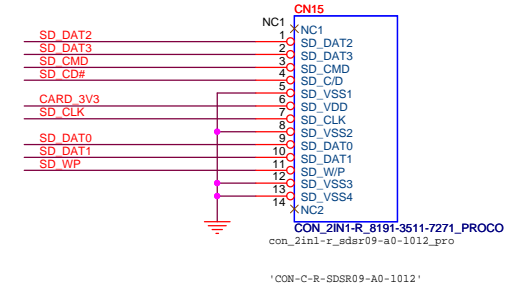

SATA HDD

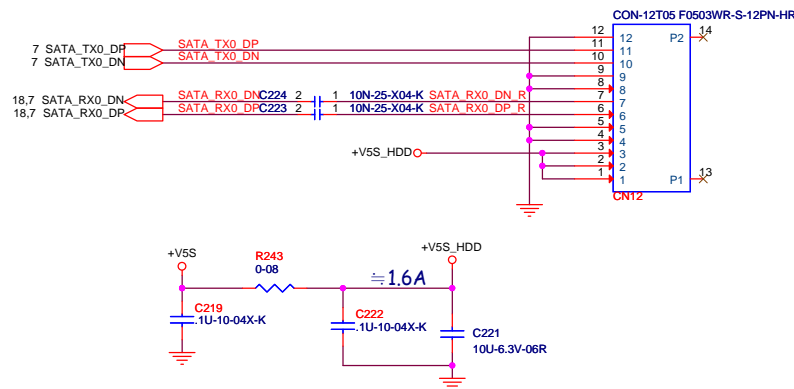

EMMC (Option)

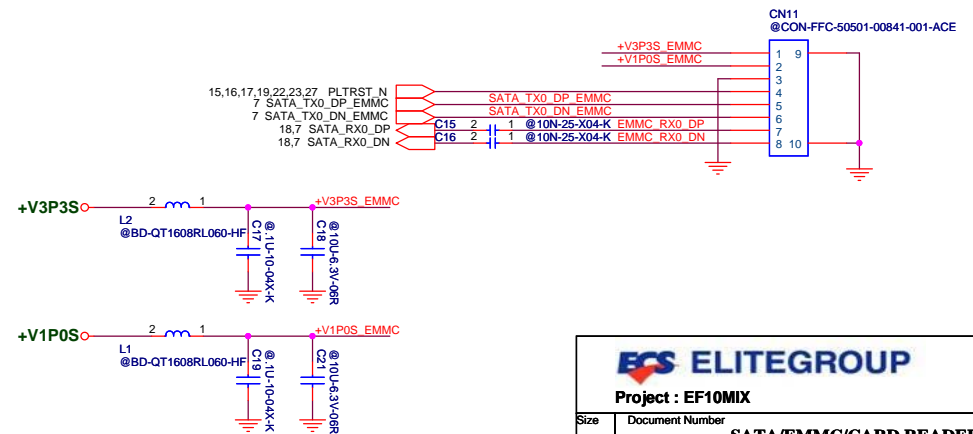

ELITEGROUP

Project : EF10MIX

Size	Document Number	Rev
	SATA/EMMC/CARD READER	01
Date:	Monday, December 16, 2013	Sheet 18 of 35

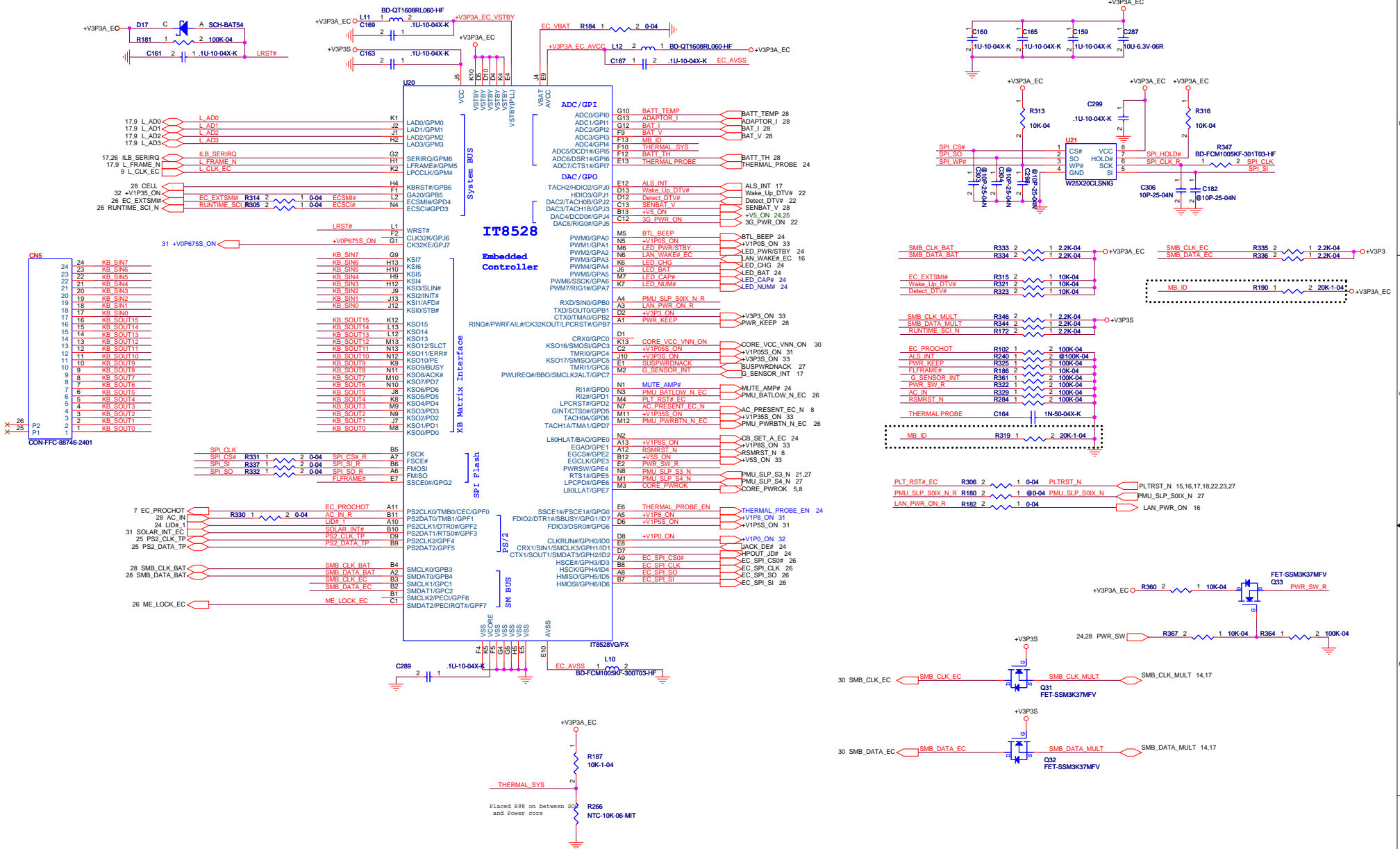

eDP / LVDS conn.

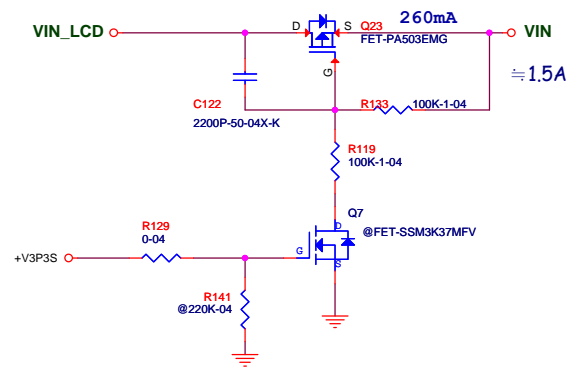
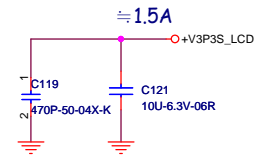
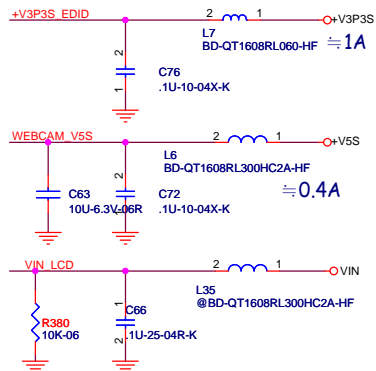
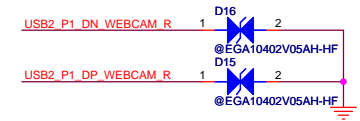
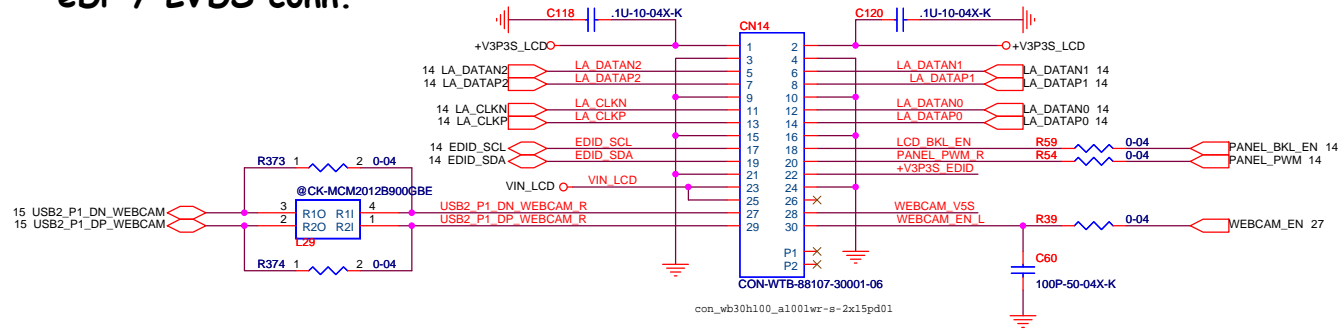

ELITEGROUP

Project : EF10MIX

Size	Document Number	Rev
	LVDS Con.	01
Date:	Monday, December 16, 2013	Sheet 20 of 35

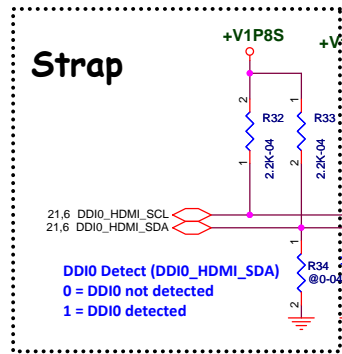

HDMI Cost Reduced Level Shifter

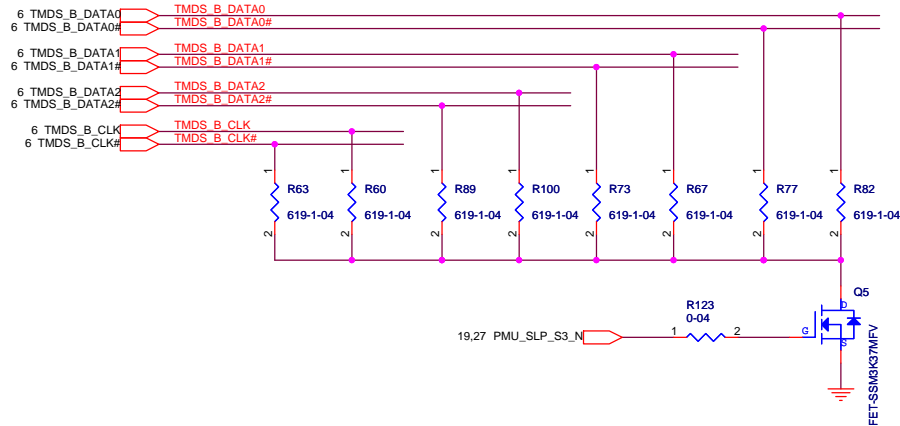

HDMI Conn. USB/HDMI Port option one

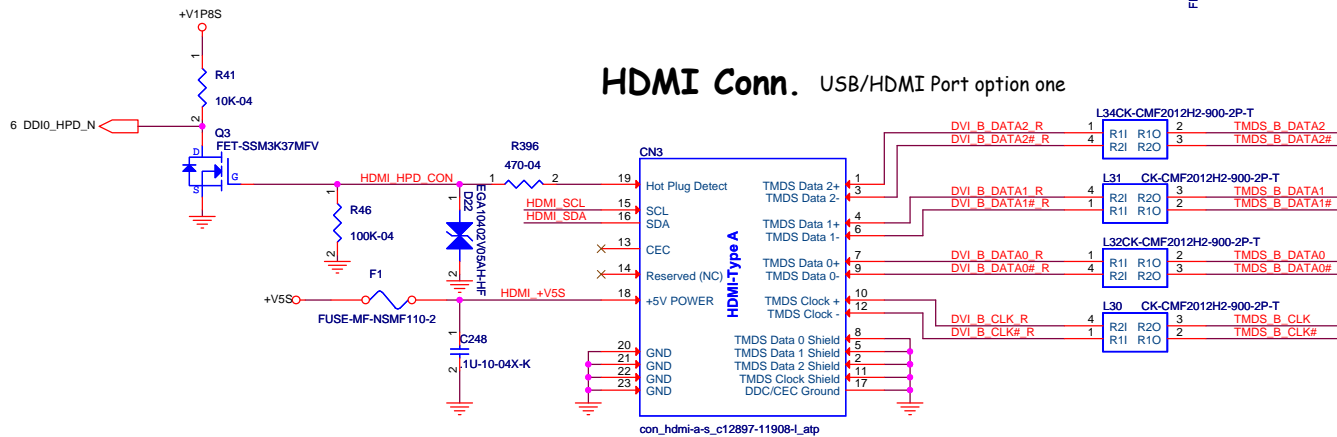

Project : EF10MIX

Size	Document Number	Rev
	HDMI Con.	01
Date:	Monday, December 16, 2013	Sheet 21 of 35

NGFF_3G / DTV

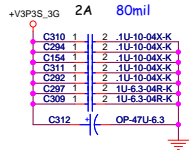
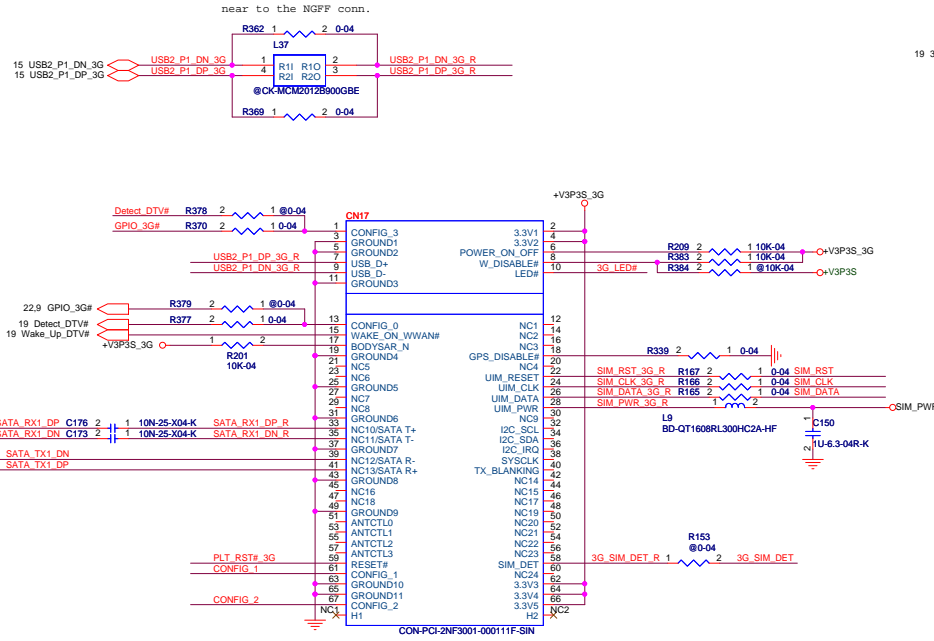

Close to 3G NGFF_CONN

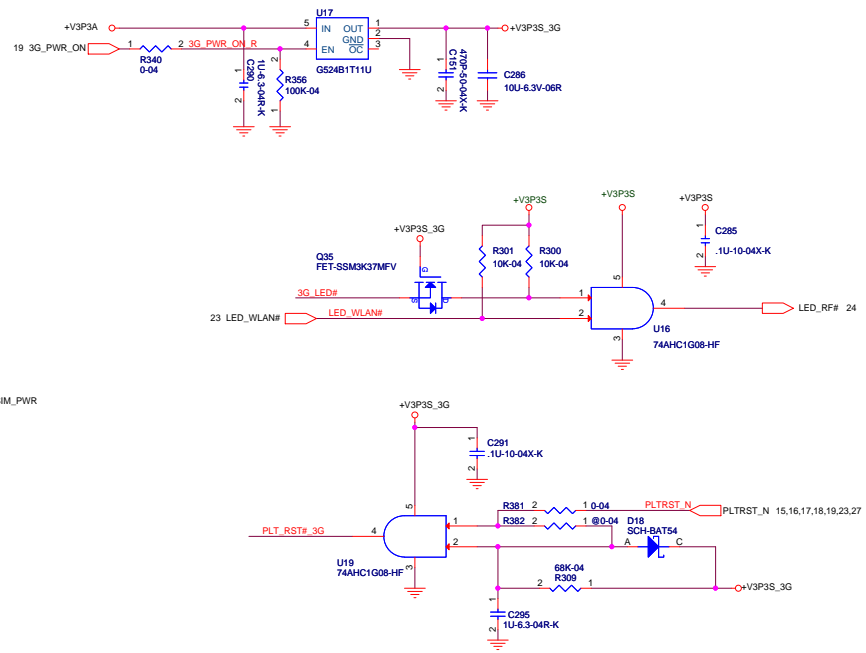
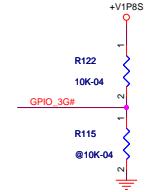

SIM_CARD

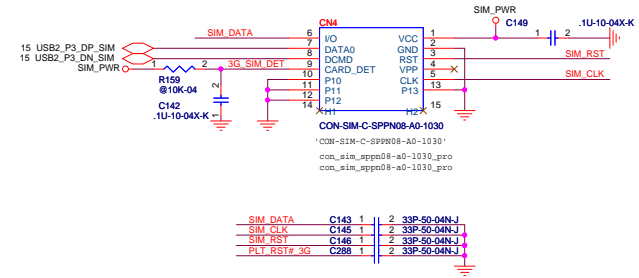

cap near to the NGFF conn. pin

Module type and Main host interface	CONFIG_0 (Pin 13) 21	CONFIG_1 (Pin 61) 69	CONFIG_2 (Pin 67) 75	CONFIG_3 (Pin 1)
SSD-SATA (SSD)	NC	GROUND	GROUND	GROUND
WWAN-PCIe	GROUND	GROUND	NC	GROUND
WWAN-SSIC (3G)	NC	GROUND	GROUND	GROUND
WWAN-USB3.0	GROUND	GROUND	GROUND	NC
WWAN-USB3.0 (DTV)	GROUND	NC	NC	NC

GPIO_3G	DEVICE
High	DTV
Low	3G/SSD

NGFF WLAN

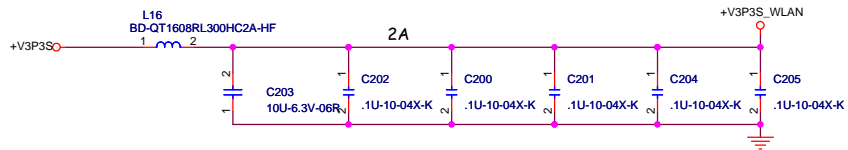
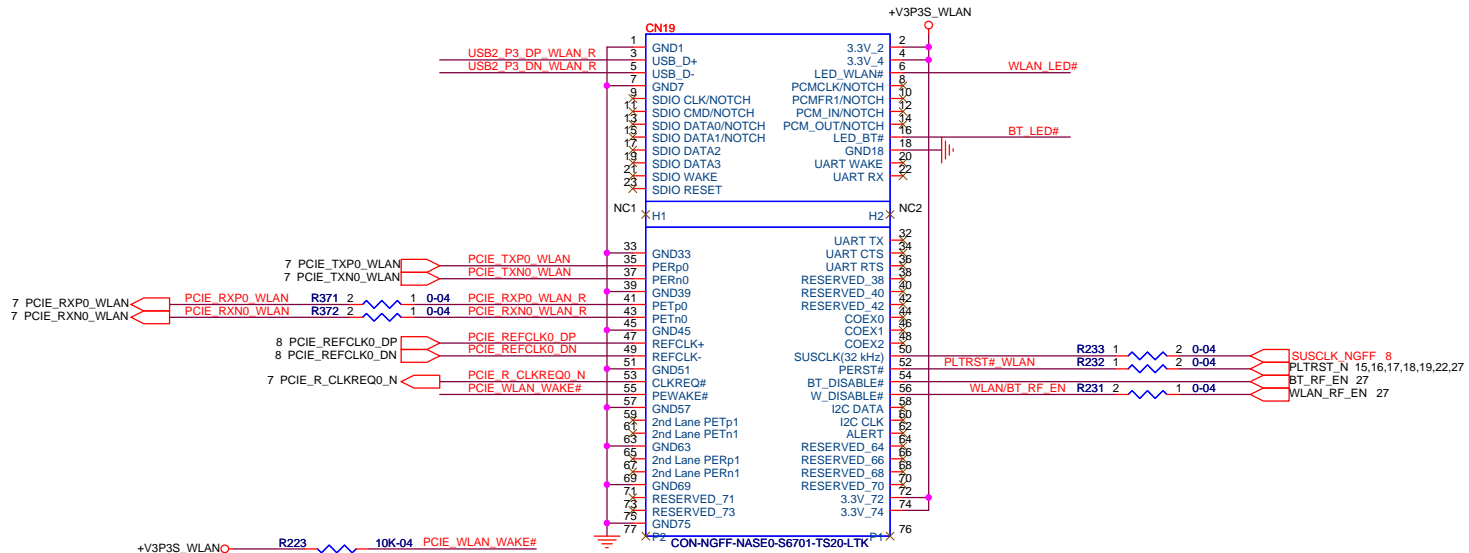
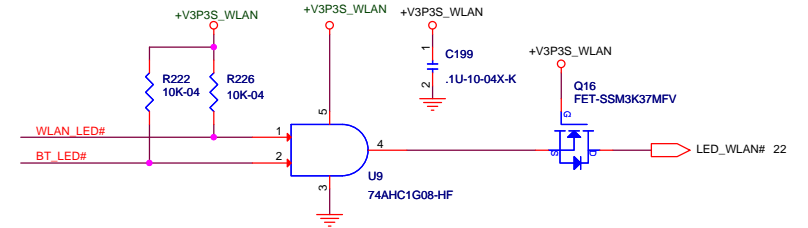
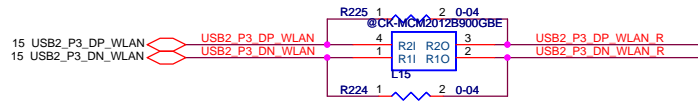

ELITEGROUP

Project : EF10MIX

Size	Document Number	Rev
	WIRELESS CON	01
Date:	Monday, December 16, 2013	Sheet 23 of 35

Quick Key

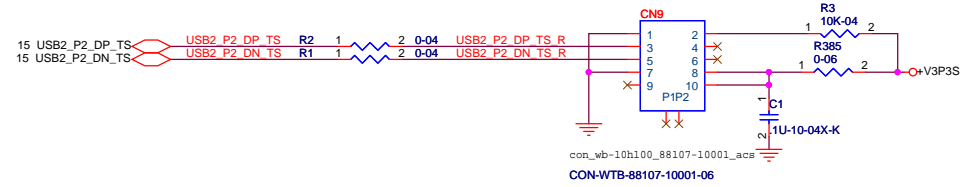
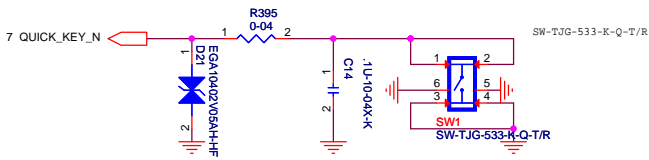

HALL Sensor

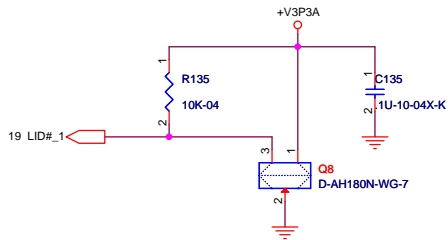

Touch panel

Sensor Hub

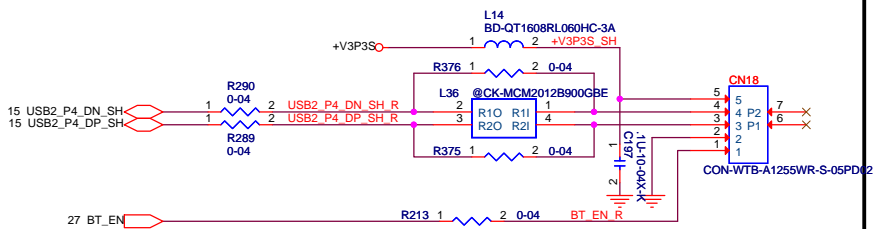

BT_EN = low disable BT.
BT_EN = high enable BT.

IO CONN.

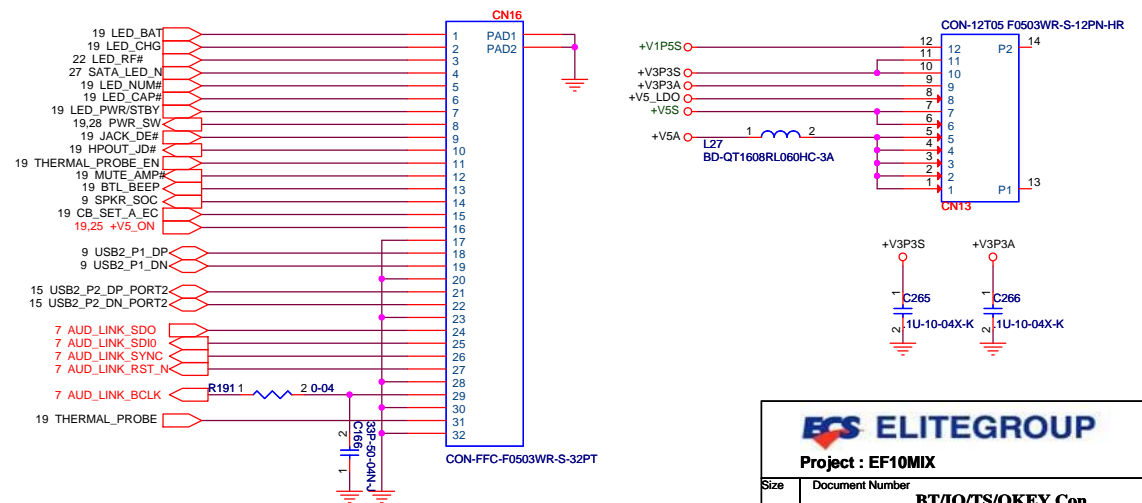

ELITEGROUP

Project : EF10MIX

Size	Document Number	Rev
	BT/IO/TS/QKEY Con.	01
Date:	Monday, December 16, 2013	Sheet 24 of 35

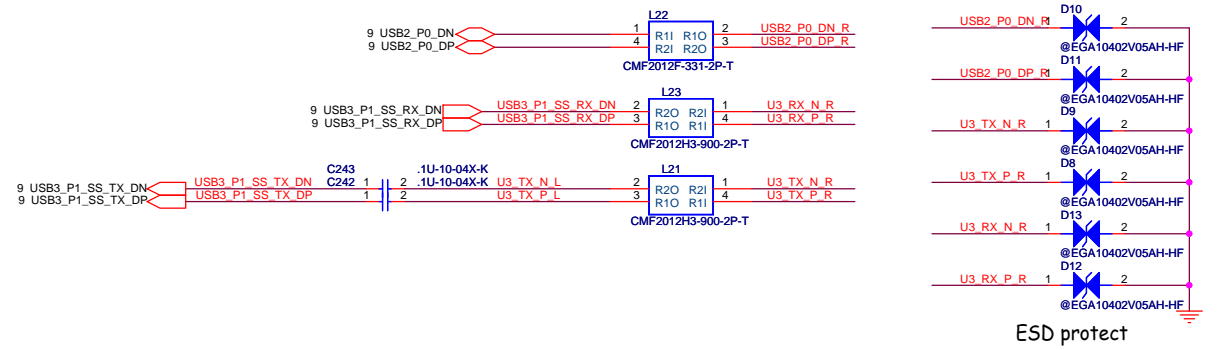
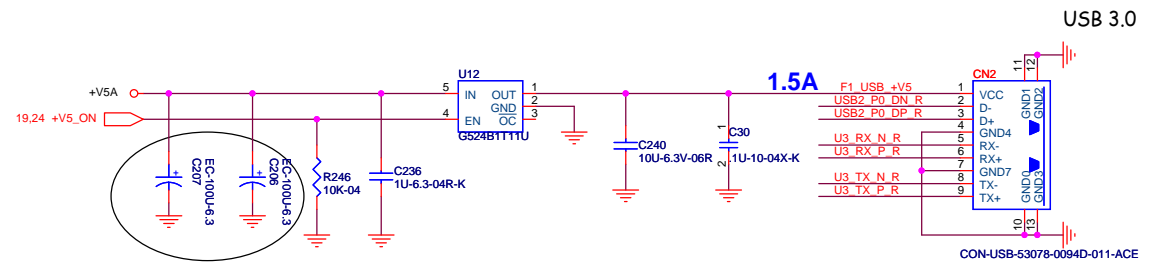

Touch PAD

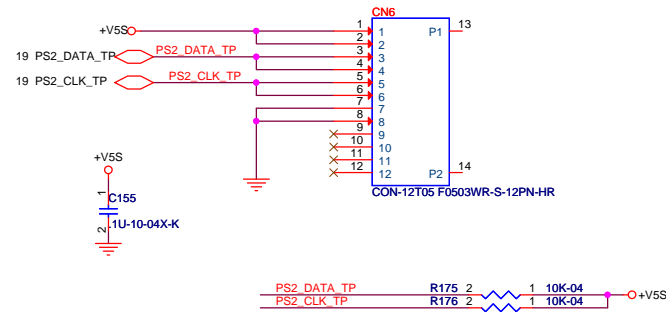

EC to SOC

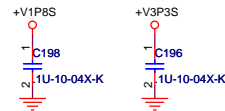
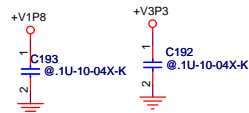
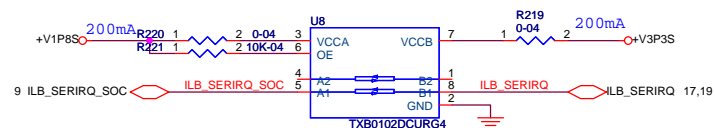
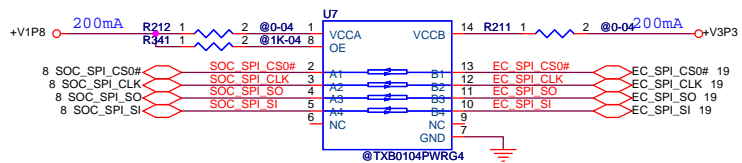
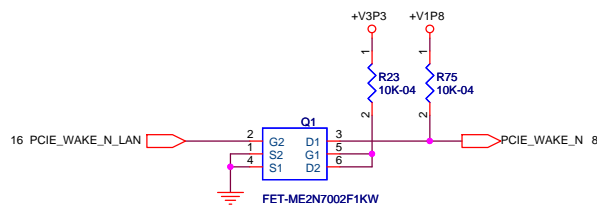
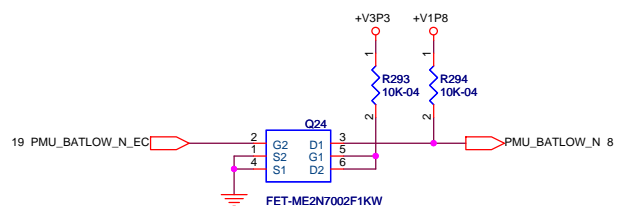
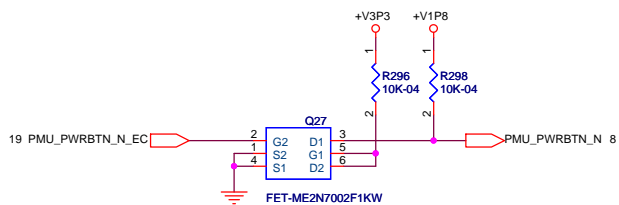
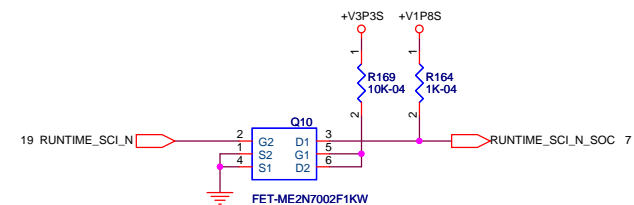
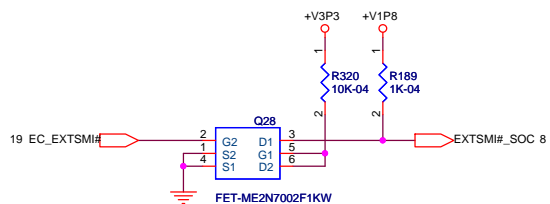
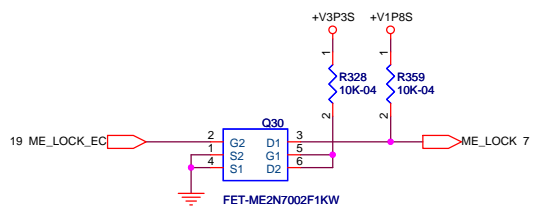

ELITEGROUP

Project : EF10MIX

Size	Document Number	Rev
	LEVEL SHIFT (EC)	01
Date:	Monday, December 16, 2013	Sheet 26 of 35

SOC to EC

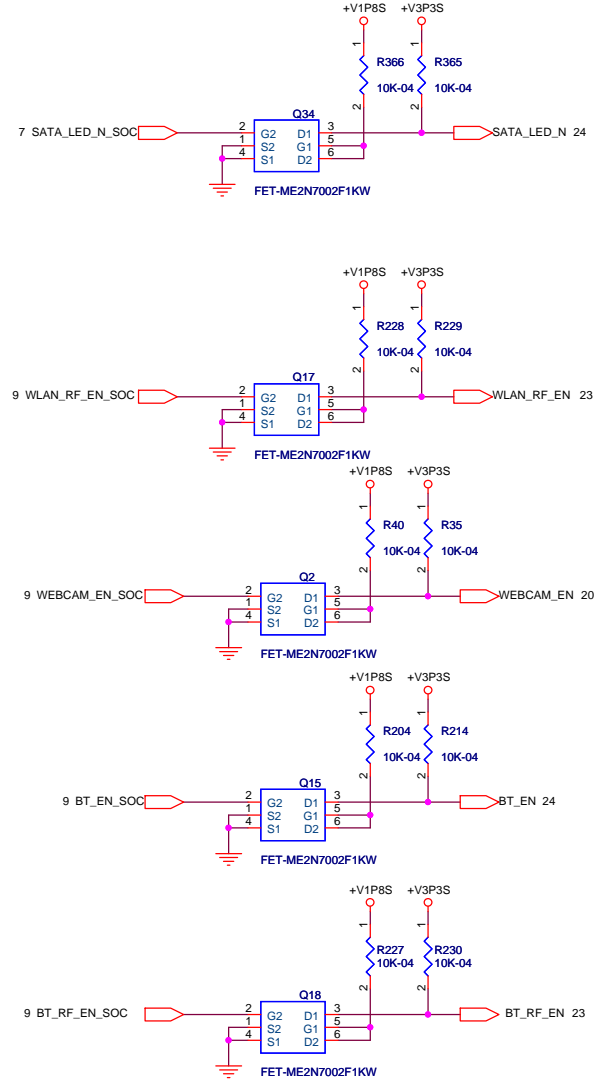
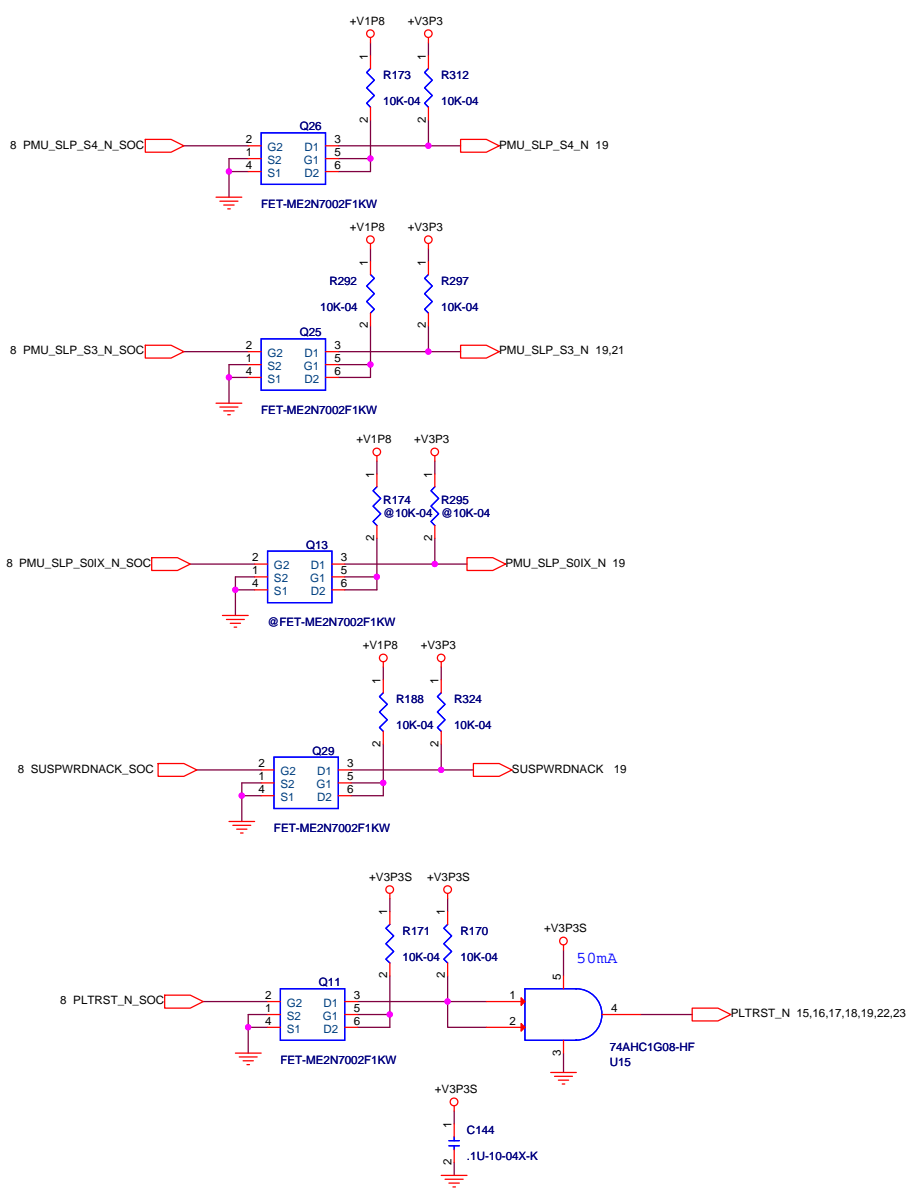

ELITEGROUP

Project : EF10MIX

Size	Document Number	Rev
	LEVEL SHIFT (SOC)	01
Date:	Monday, December 16, 2013	Sheet 27 of 35

BAT IN

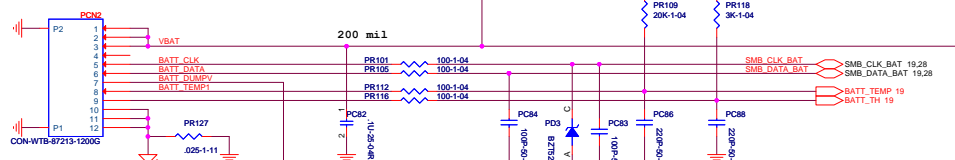

ADAPTOR_I

0A-->1.657V
 0.5A-->1.533V
 1A-->1.452V
 1.5A-->1.351V
 2A-->1.249V
 2.5A-->1.142V
 3A-->1.035V
 3.5A-->0.924V
 4A-->0.81V

Charge / Discharge Detect

6A-->0V
 5.5A-->2.57815V
 +2.5A-->2.4324V
 +2A-->2.2866V
 +1A-->1.99519V
 +0.25A-->1.7765V
 0A-->1.7037V
 -3A-->0.82926V

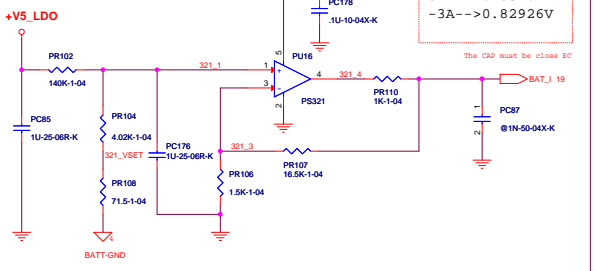
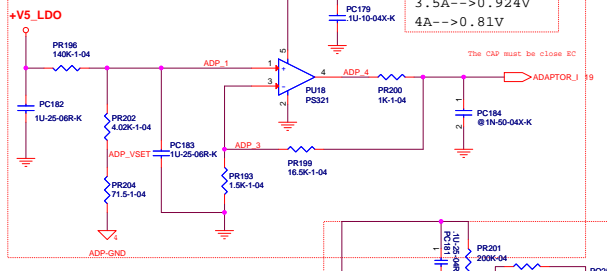
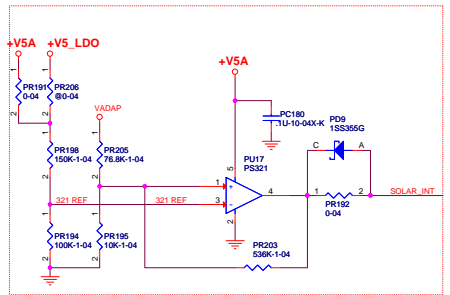

DC IN Conn

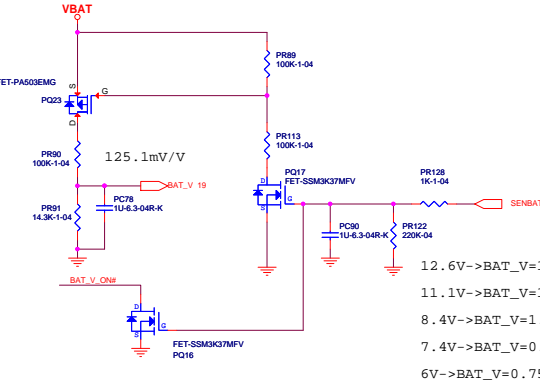
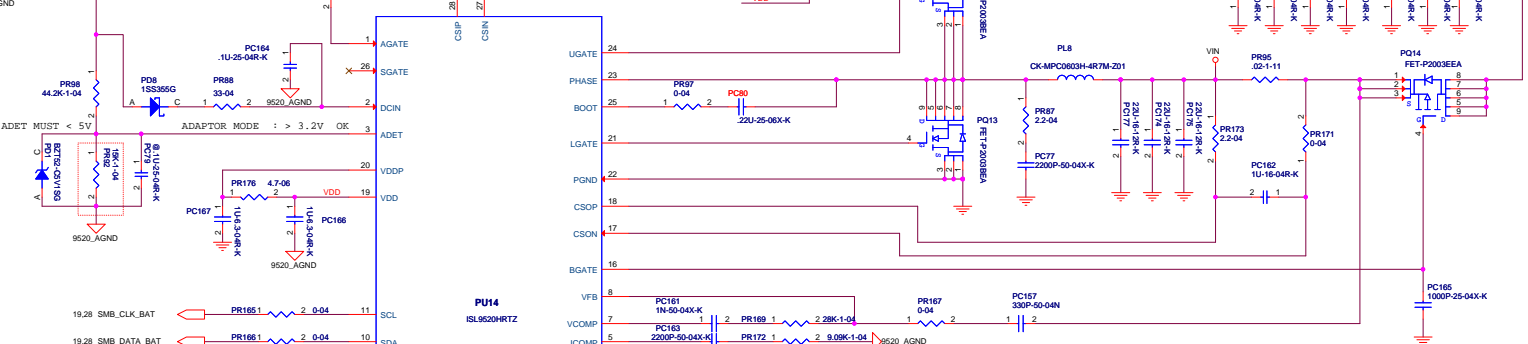
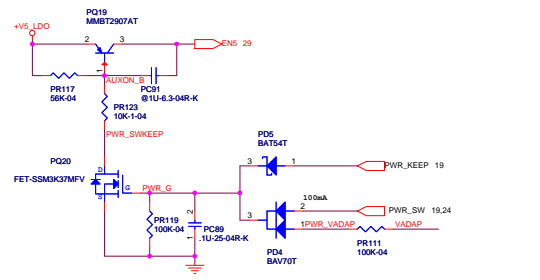
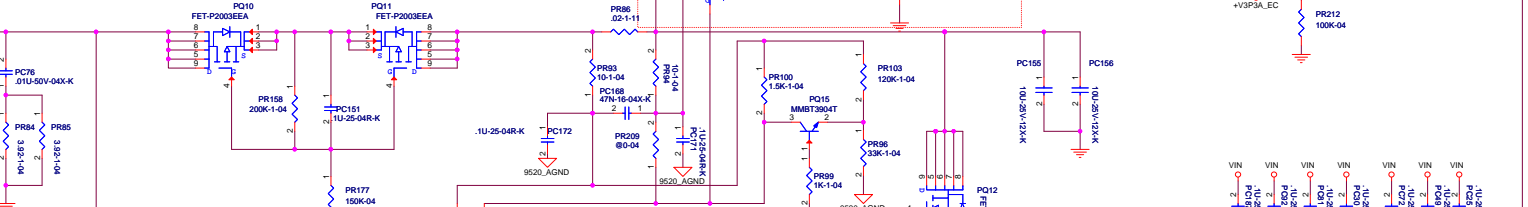
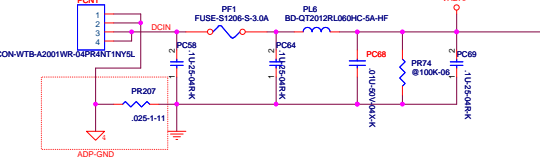

12.6V->BAT_V=1.576V
 11.1V->BAT_V=1.388V
 8.4V->BAT_V=1.05V
 7.4V->BAT_V=0.9258V
 6V->BAT_V=0.75V

3.3VAA

PIN 6 Cell Float 4cell ,Pull VSM3 3cell ,pulling low 2-cell

BATTERY DISCHARGE CURRENT : RESERVE TEST POINT AS ADAPTOR_I CONNECT TO EC ADC PIN

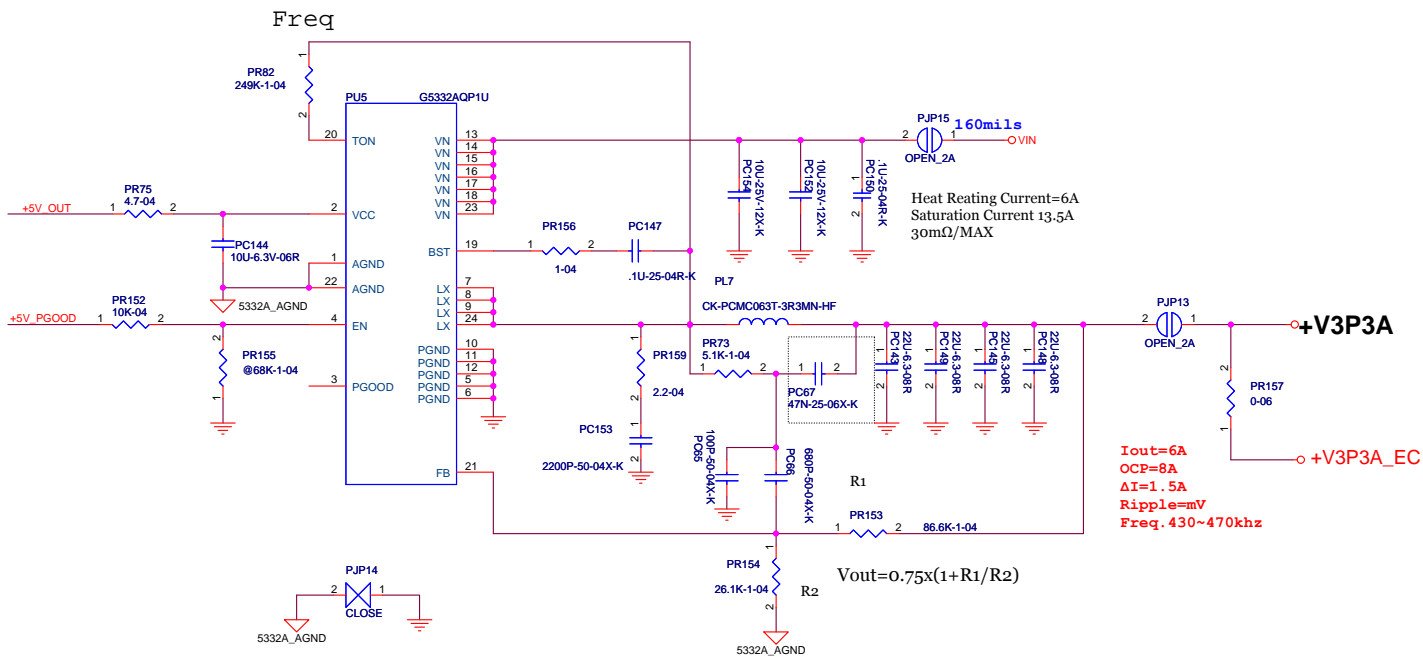
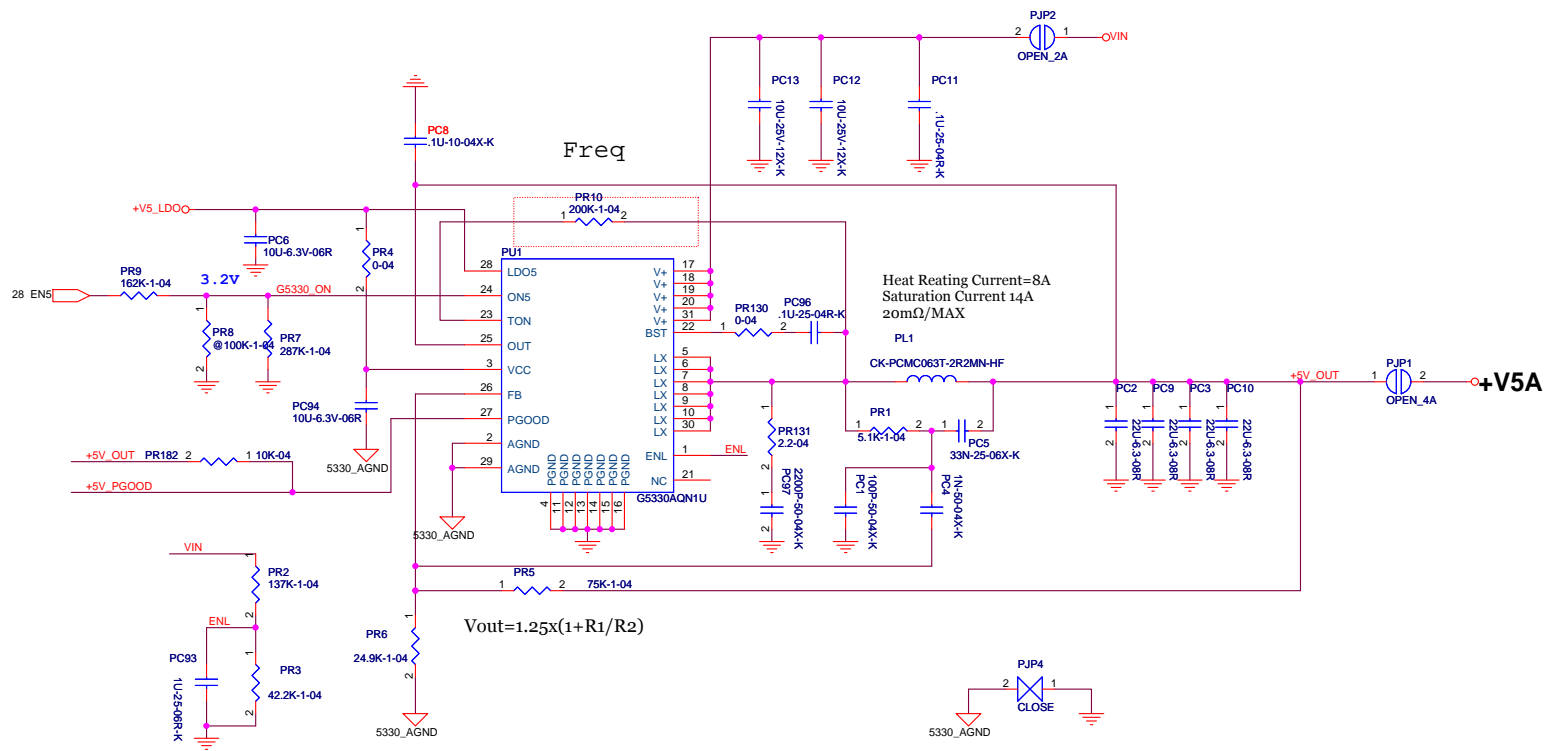

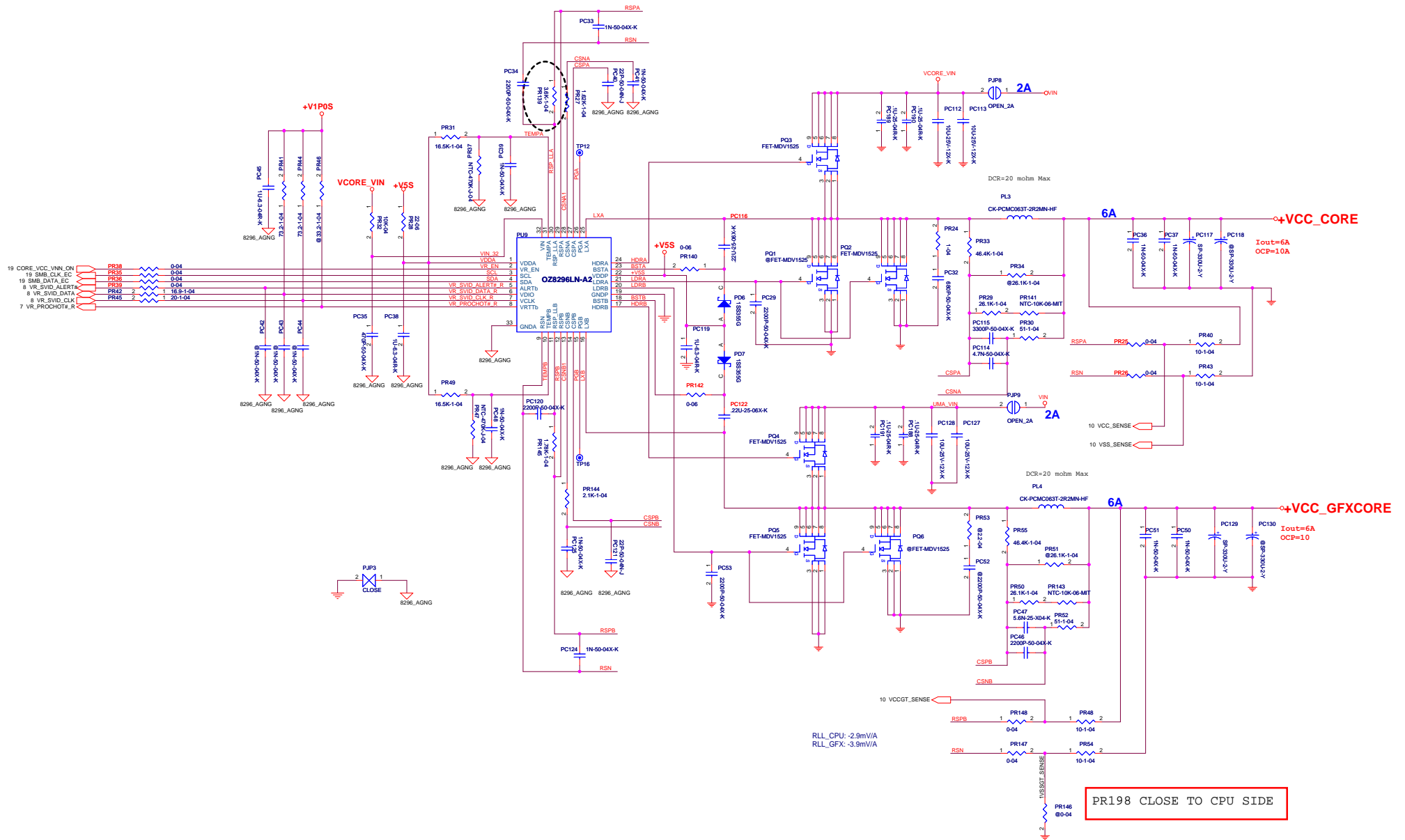

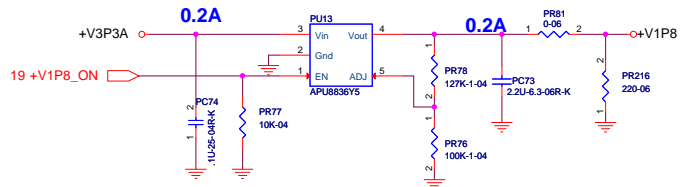

$$V_{out} = 0.8(1 + R1/R2)$$

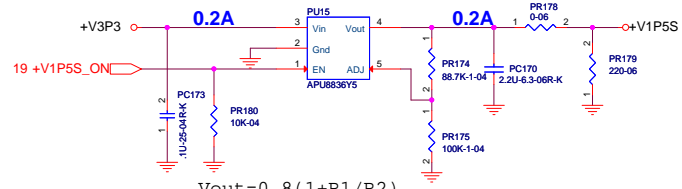

$$V_{out} = 0.8(1 + R1/R2)$$

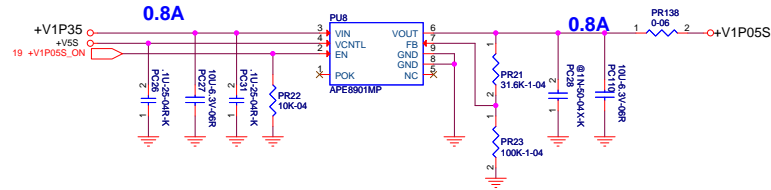
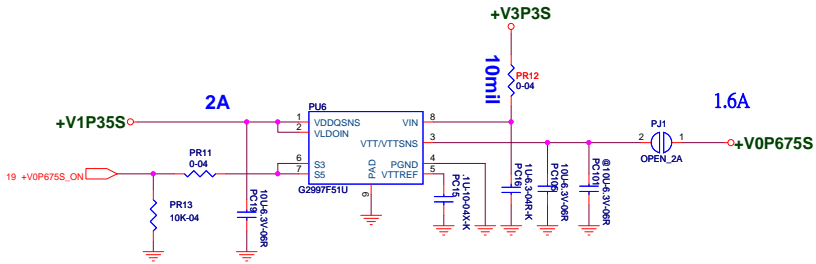

$$V_{out} = 0.8(1 + R1/R2)$$

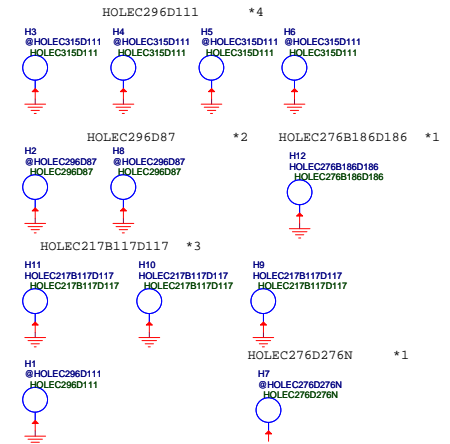

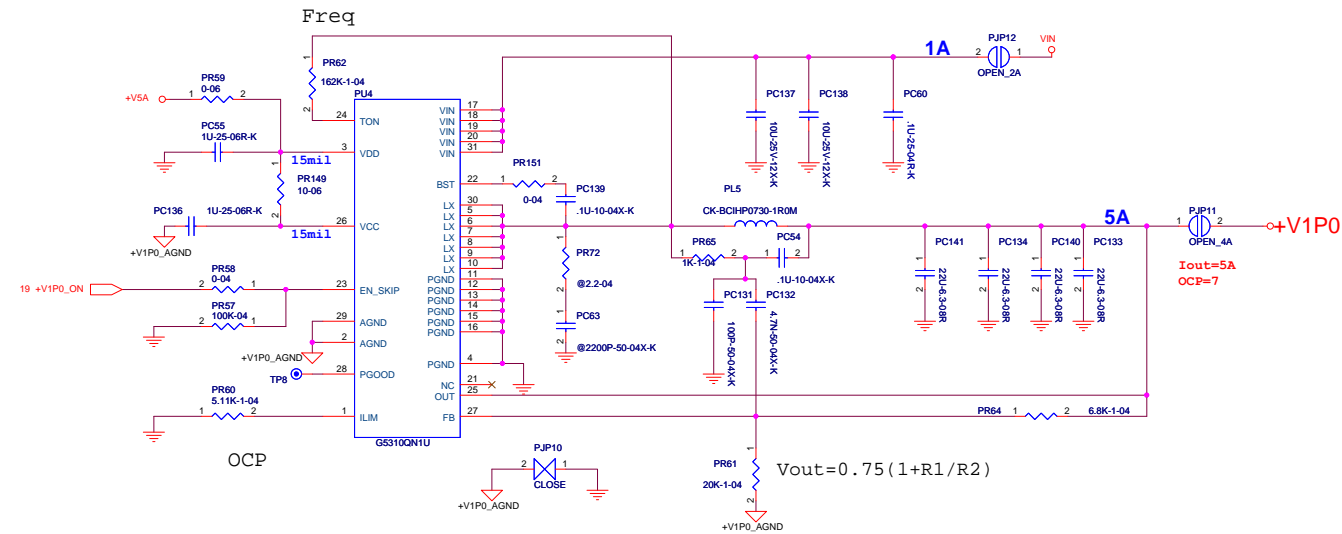
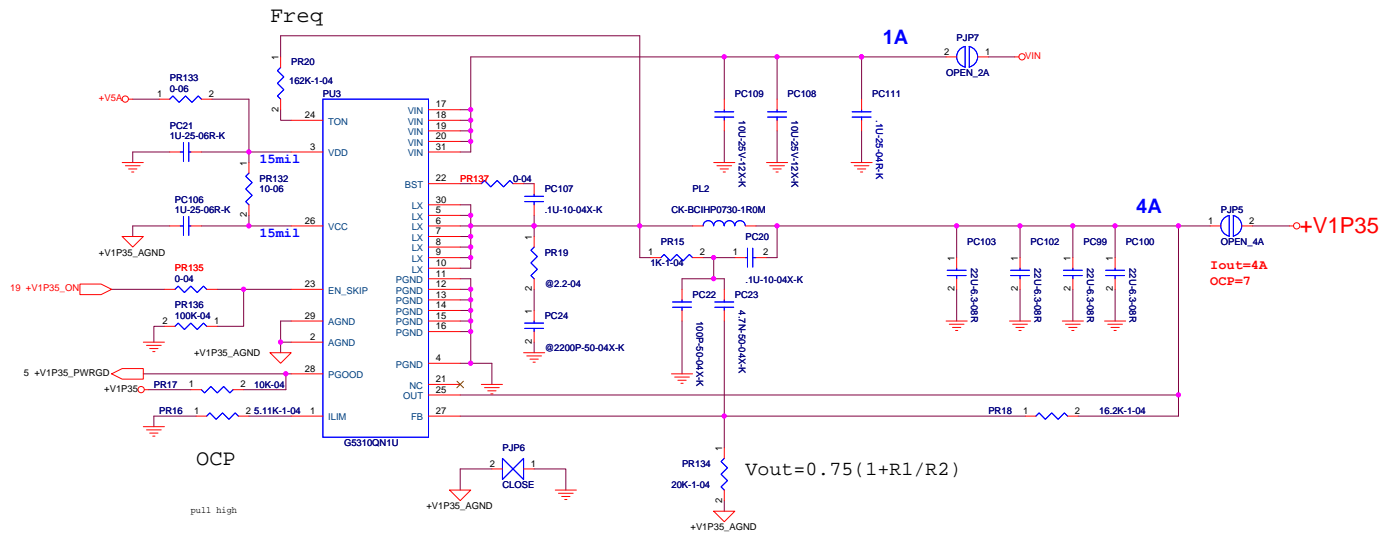

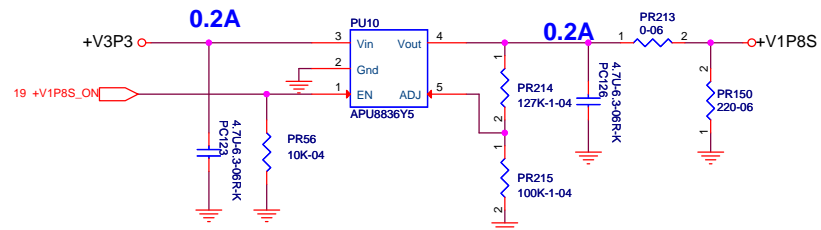
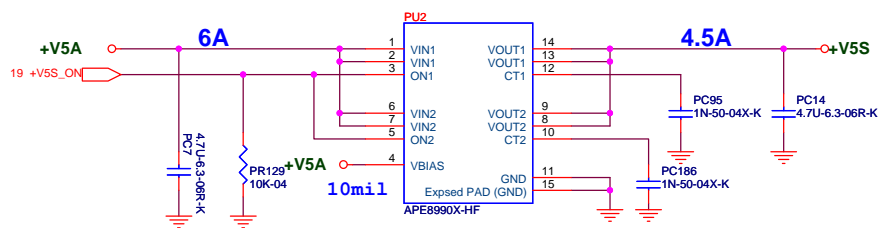
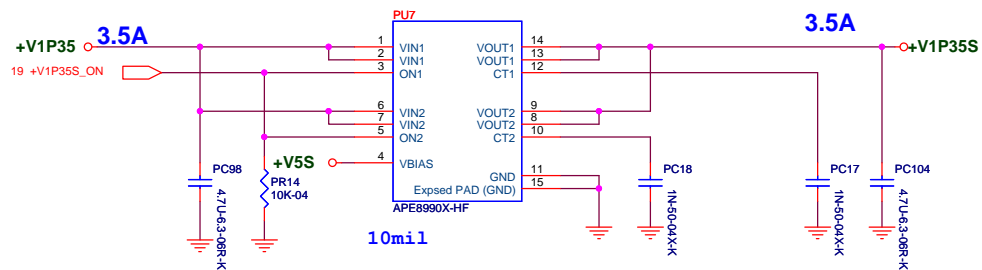
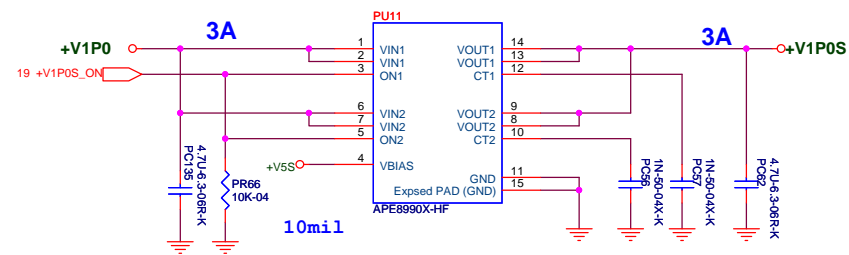
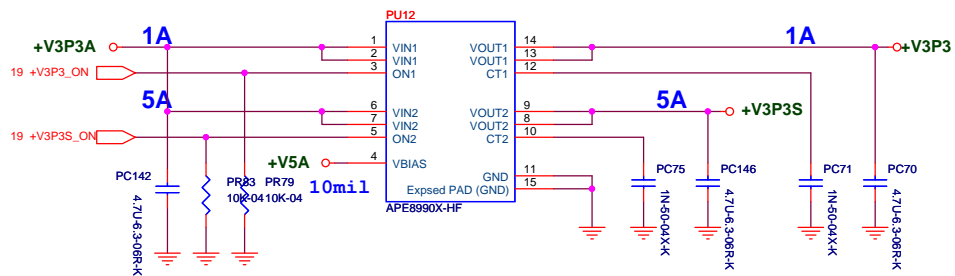

$$V_{out} = 0.8(1 + R1/R2)$$



Project : EF10MIX

Size	Document Number	Rev
	Power Switch	01
Date:	Monday, December 16, 2013	Sheet 33 of 35

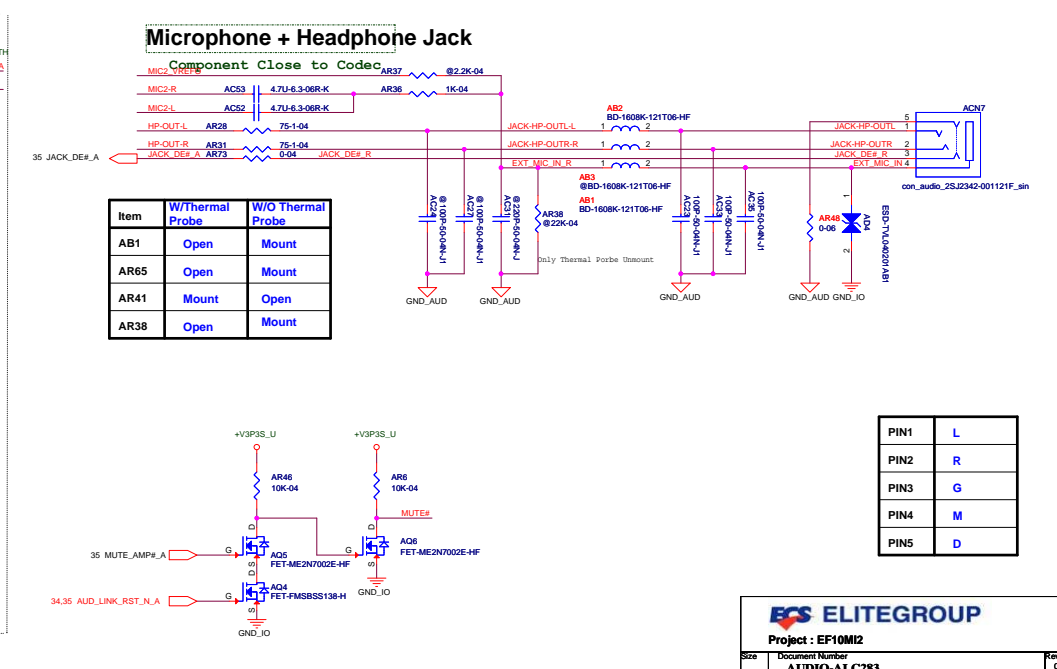
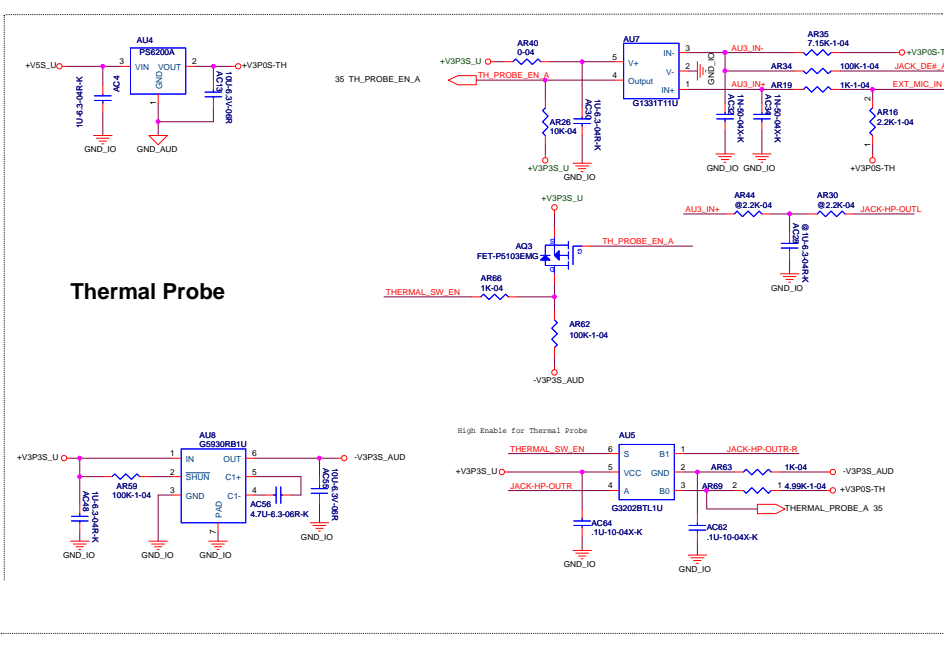
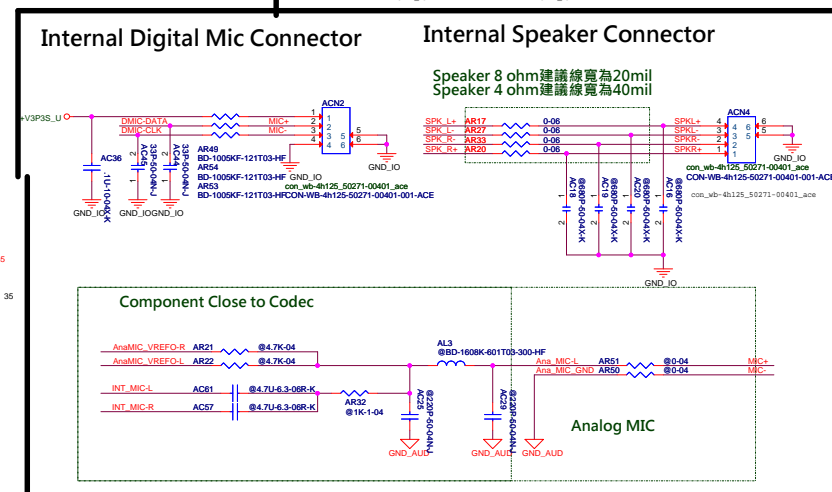
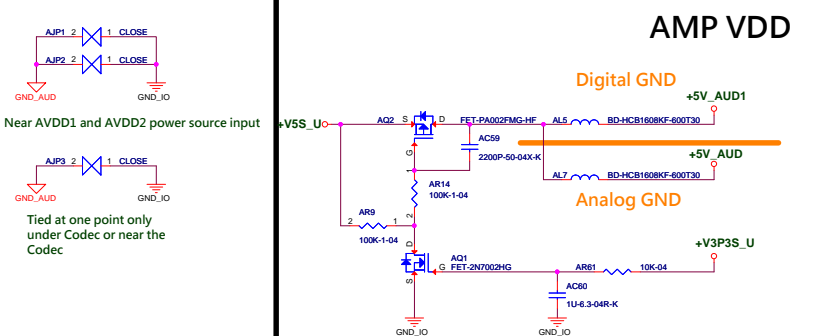
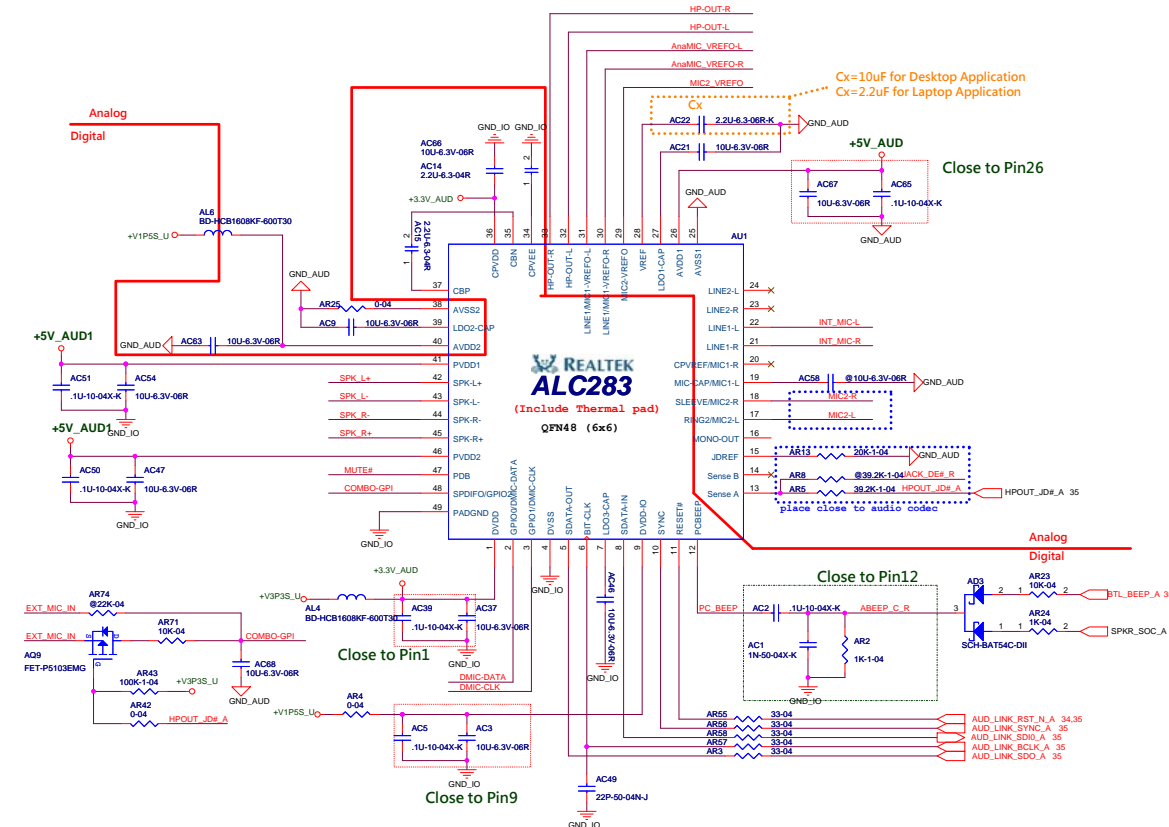

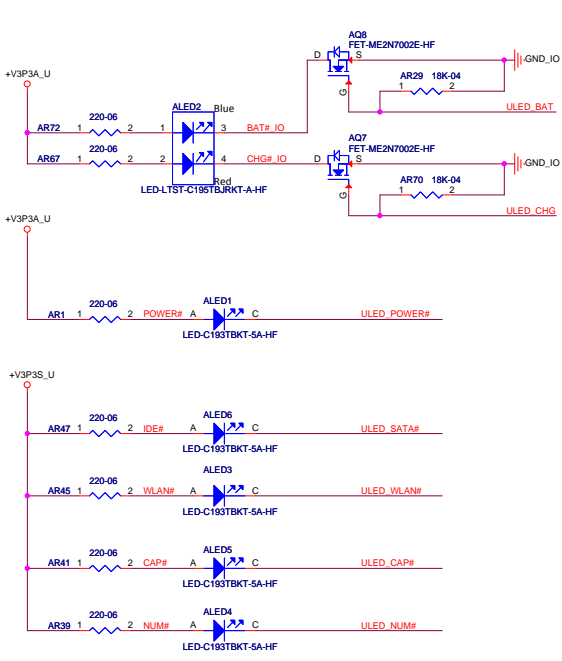

Power Button

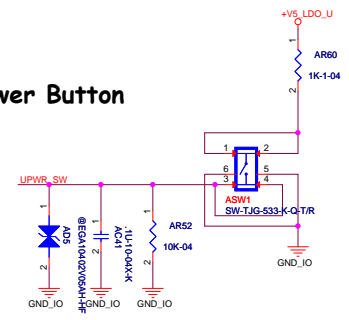

USB_LED CONN.

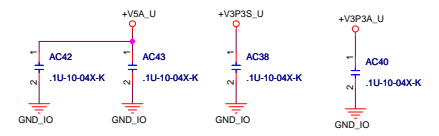
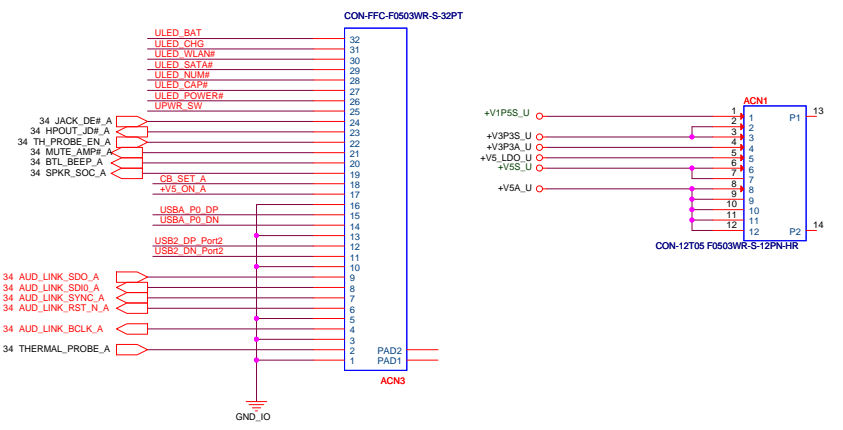

USB R-Port

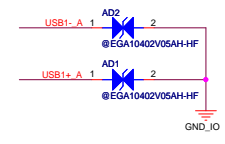
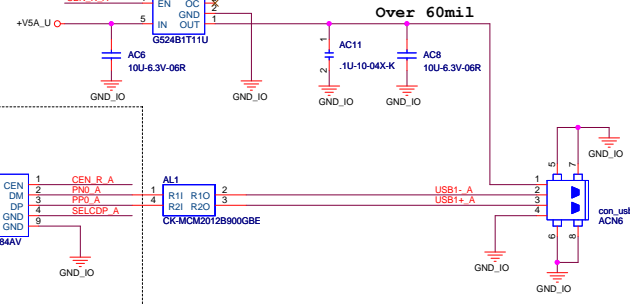
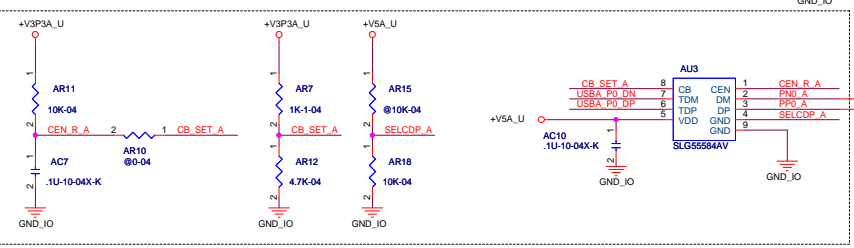

IO CONN.

USB_A_P0_DN	AR64	1	2	@0-04	P0N_A
USB_A_P0_DP	AR65	1	2	@0-04	PP0_A
+V5_ON_A	AR75	1	2	@0-04	CEN_R_A

