

PAGE CONTENT

1.	COVER PAGE
2.	SEQUENCE DIAGRAM
3.	SYSTEM BLOCK DIAGRAM
4.	CPU CEDARVIEW-1/4
5.	CPU CEDARVIEW-2/4
6.	CPU CEDARVIEW-3/4
7.	CPU CEDARVIEW-4/4
8.	TRGERPOINT 1/4
9.	TRGERPOINT 2/4
10.	TRGERPOINT 3/4
11.	TRGERPOINT 4/4
12.	DDR3 SODIMM
13.	CLOCK GENERATOR
14.	LCD / WEB CAM / SATA
15.	CRT
16.	HDMI
17.	USB / IO CON
18.	CARD READER RST-5138
19.	LAN-RTL8105E-VL-CG
20.	WIRELESS CON
21.	3G
22.	TPM
23.	G-SENSOR
24.	EC IT8518E-CX
25.	FAN/TP/BT/LID/EMI REQUEST
26.	TRIAL PEAK CON / QKEY / EEPROM CON
27.	DEEP STANDBY
28.	VCC MOSFET
29.	VCC_CORE / GFX
30.	+V3.3 / +V5(OZ8153)
31.	+V1.5/+V1.05S (OZ8138)
32.	+V1.8S / +V0.75S
33.	DC IN / BATT IN / CHARGER
34.	POWER P-STATE

Power Rail

+VCC_CORE	Core voltage for Processor(off in S3-S5)
+VCC_GFX	GFX voltage for Processor(off in S3-S5)
+V0.75S	0.75V switched power rail(off in S3-S5)
+V1.05S	1.05V switched power rail (off in S3-S5)
+V1.5S	1.5V switched power rail (off in S3-S5)
+V1.5	1.5V power rail (off in S4-S5)
+V1.8S	1.8V switched power rail (off in S3-S5)
+V5S	5V switched power rail (off in S3-S5)
+V5	5V power rail (off in S4-S5)
+V5ALWAYS	5V always on power rail
+V3.3S	3.3V switched power rail (off in S3-S5)
+V3.3	3.3V power rail (off in S4-S5)
+V3.3ALWAYS	3.3V always on power rail

+V□□ALWAYS	Always on power rail
+V□□	Switched power rail (off in S4 - S5)
+V□□S *	Switched power rail (off in S3 - S5)

ES/EC10ISx Power on Sequence Diagram

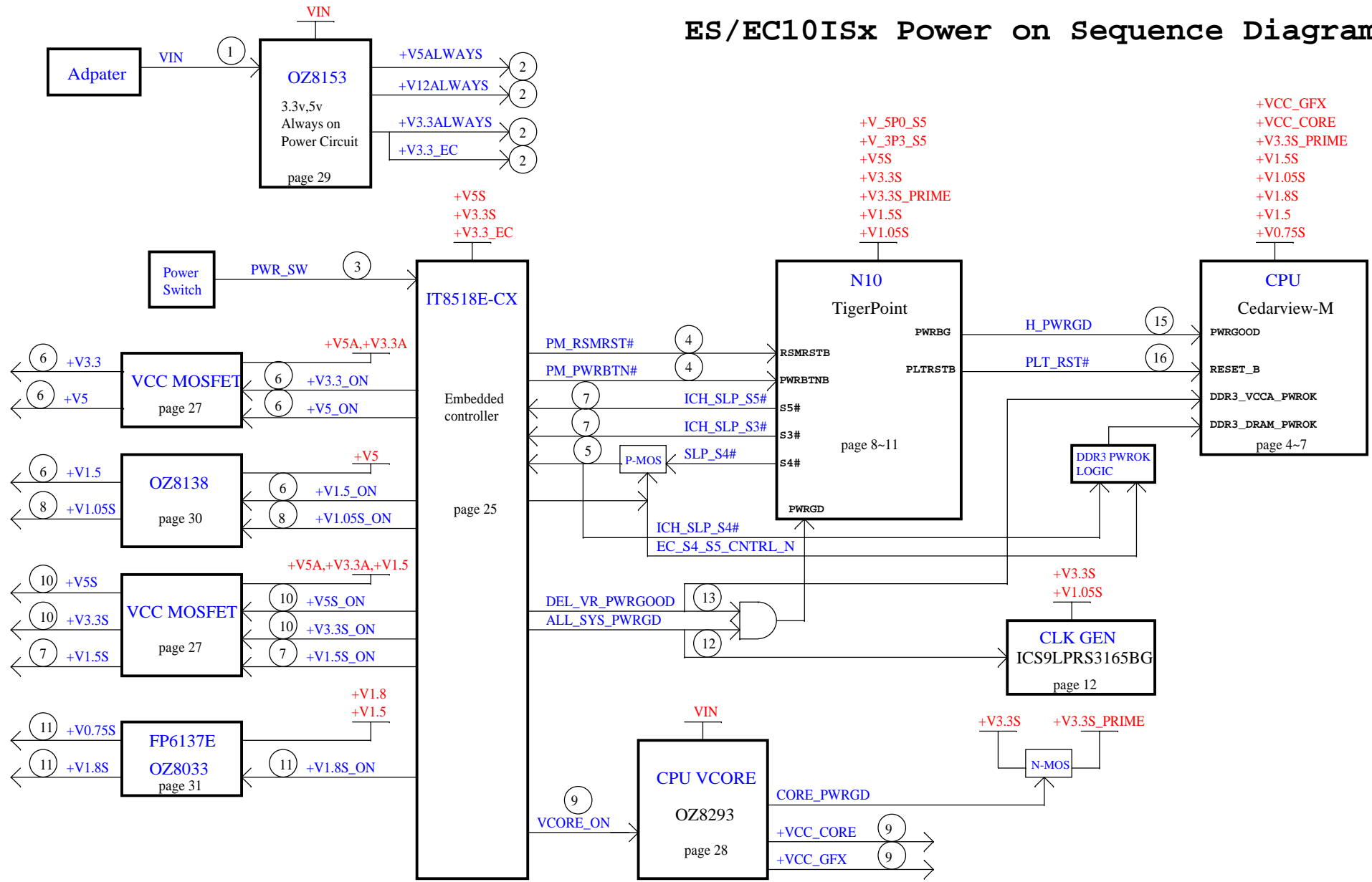

ES10/EC10 System Block Diagram

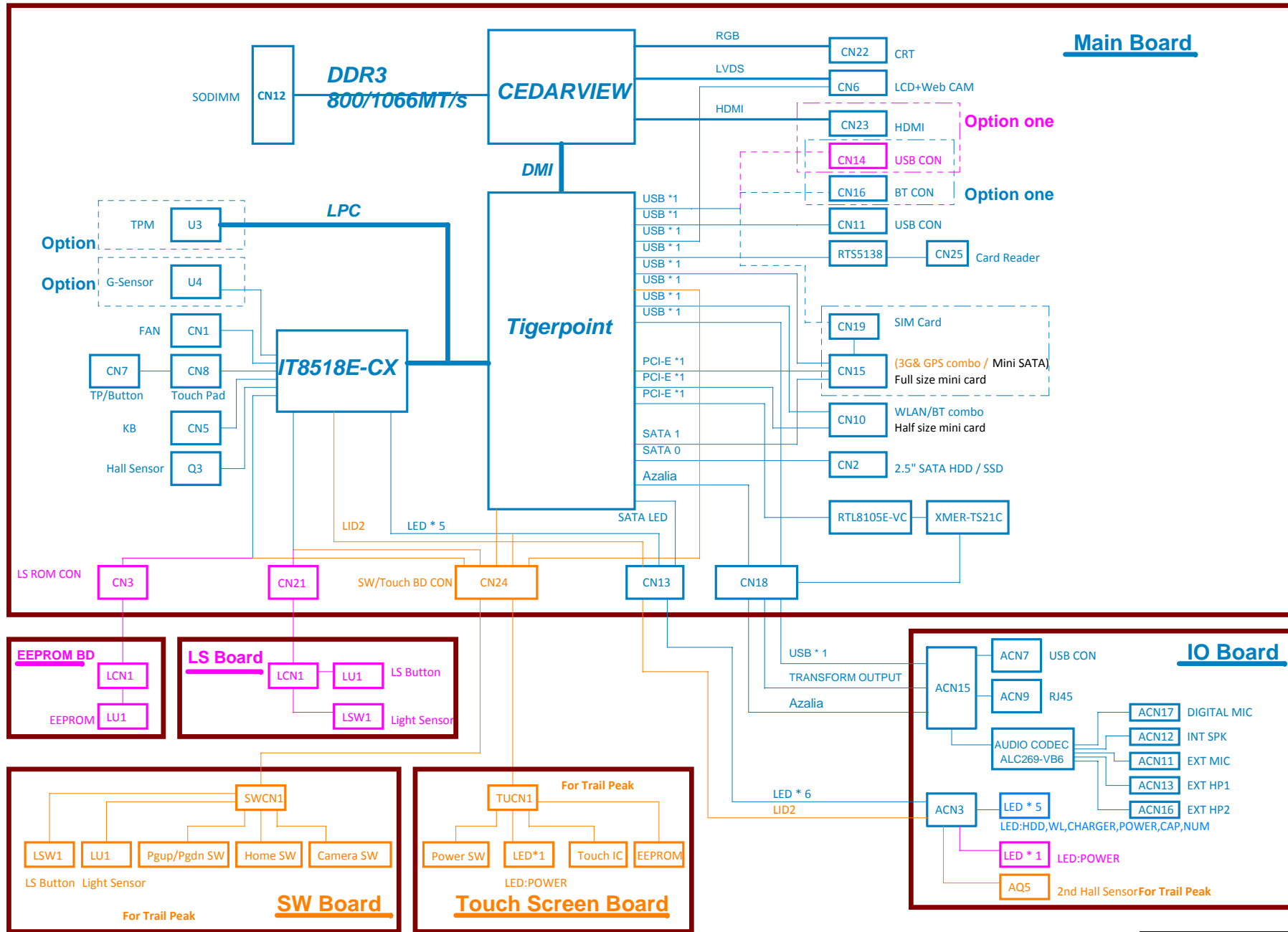

CEDARVIEW
REV = 1.10

DMI

VGA

DDI

LVDS

IHDA

1 OF 5

CEDARVIEW-M-QA7D

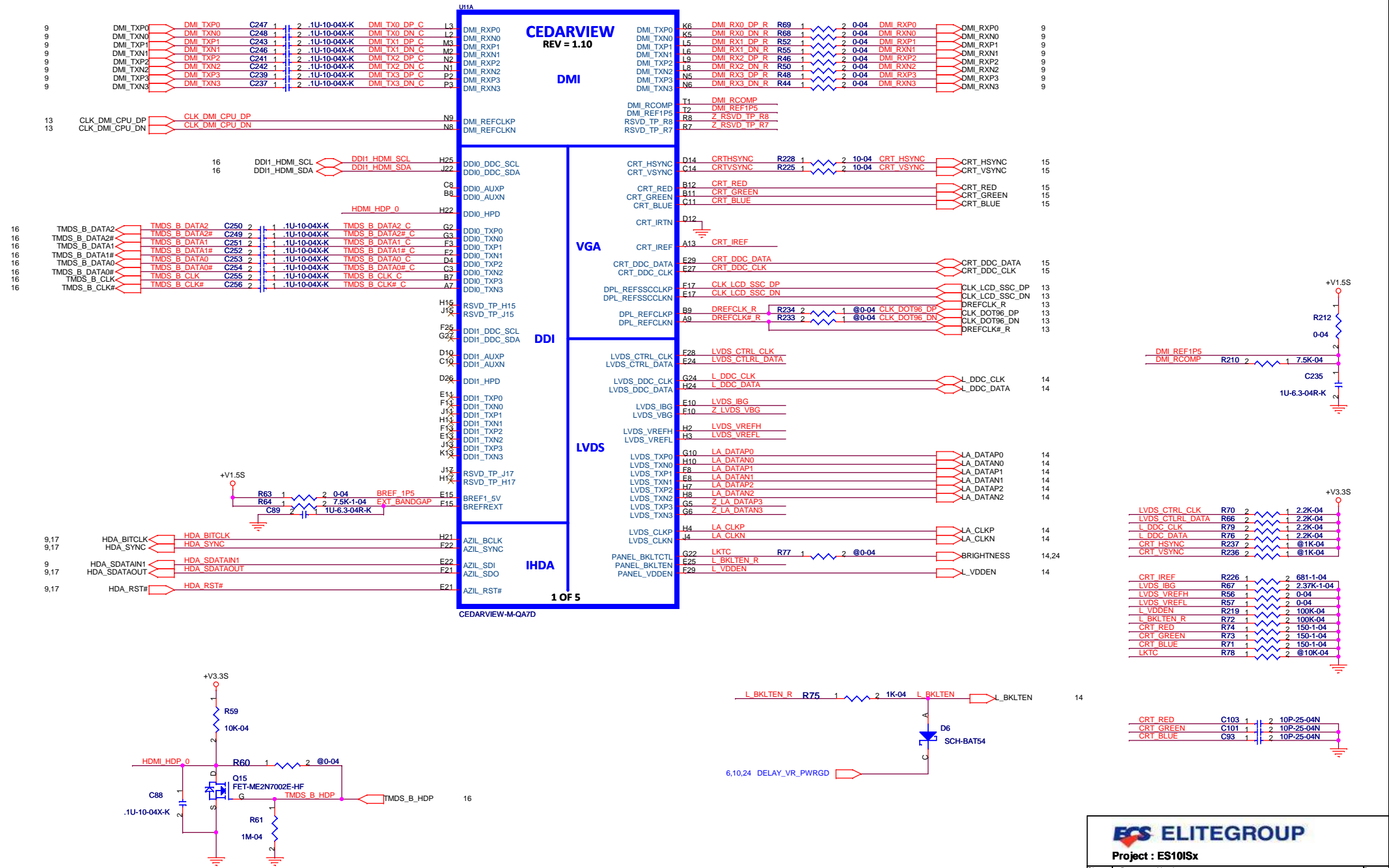

Project : ES10ISx

Size	Document Number	Rev
	CPU CEDARVIEW-1/4	A
Date:	Sunday, February 13, 2011	Sheet 4 of 34

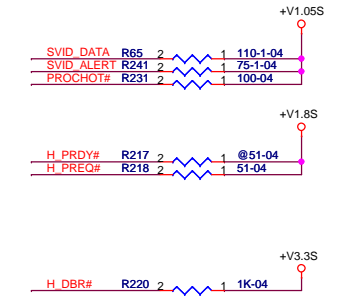
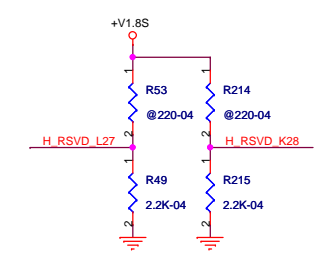
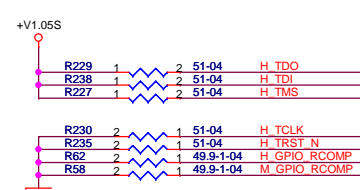
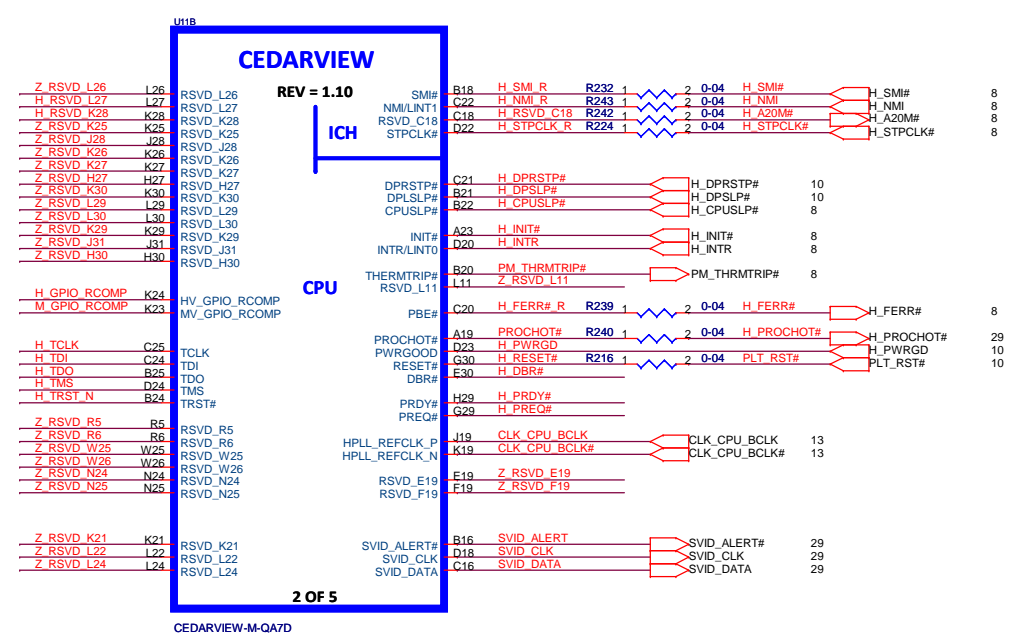
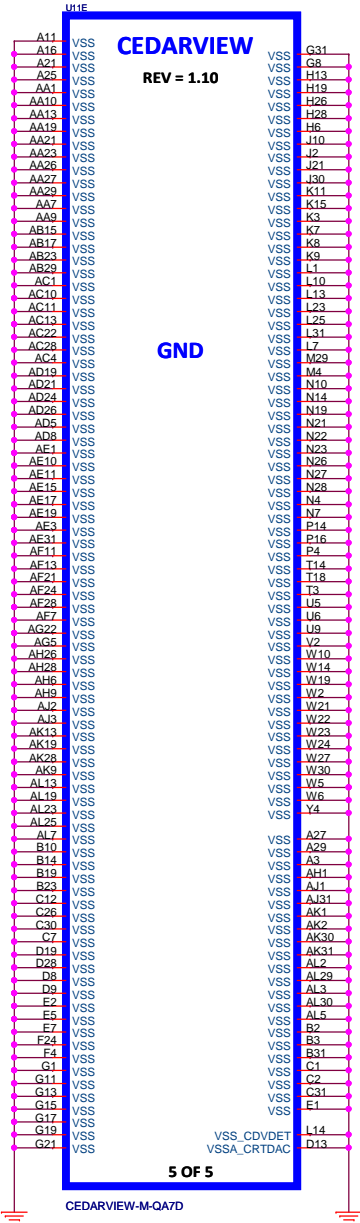

NOTE:
MAX TRACE LENGTH OF 500 MIL
AND 5 MIL SPACING
R402 for CDV and Interposer Boot

ELITEGROUP

Project : ES10ISx

Size	Document Number	Rev
	CPU CEDARVIEW-2/4	A

Date: Sunday, February 13, 2011 Sheet 5 of 34

NOTE:
PLACE TWO 1K OHM CLOSE TO CPU PINS ON M_VREF
PLACE 0.1UF CLOSE TO CPU

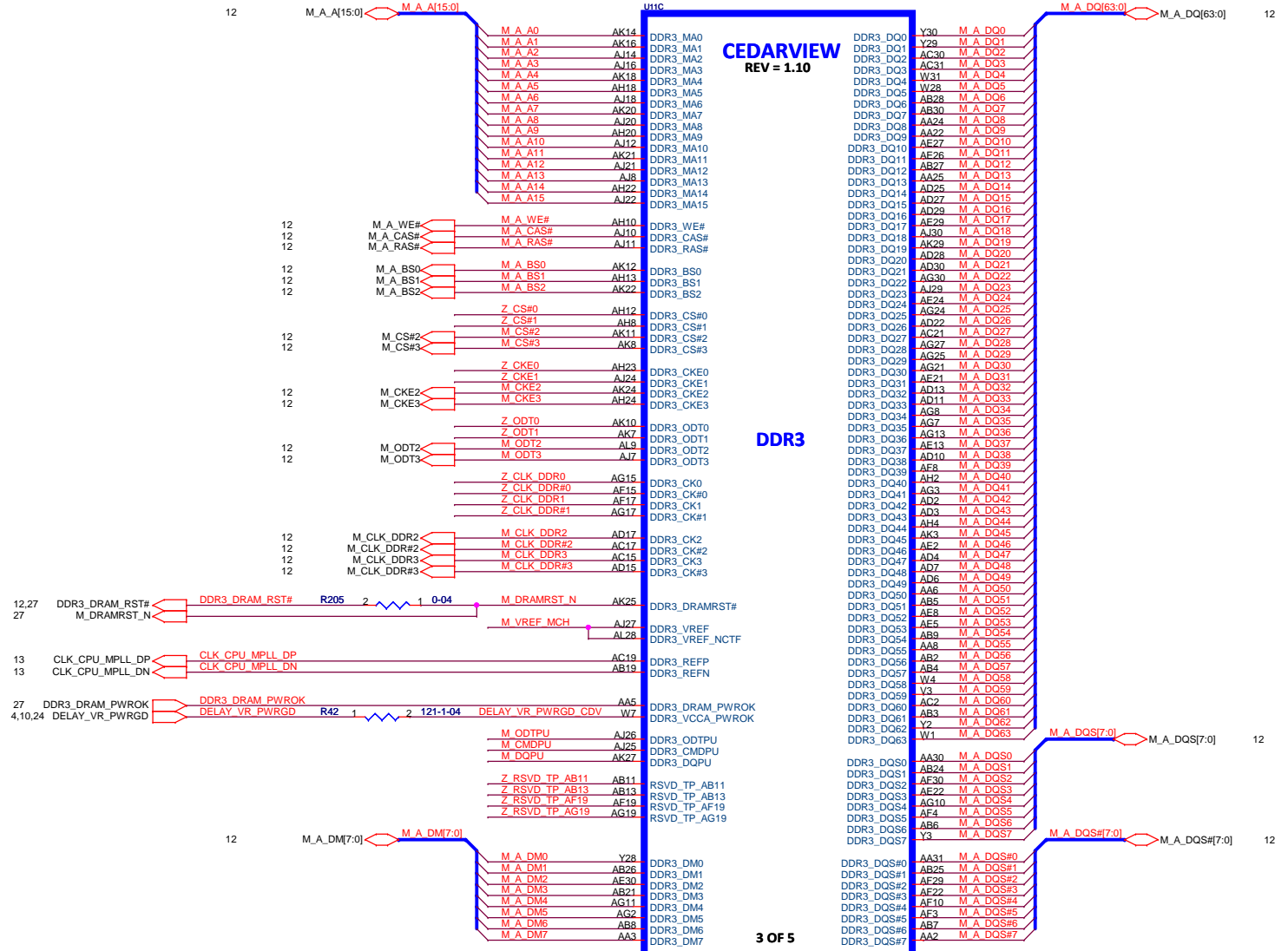
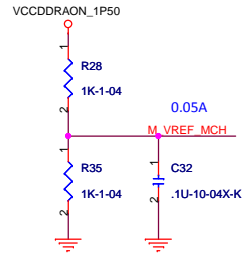

CEDARVIEW-M-QA7D

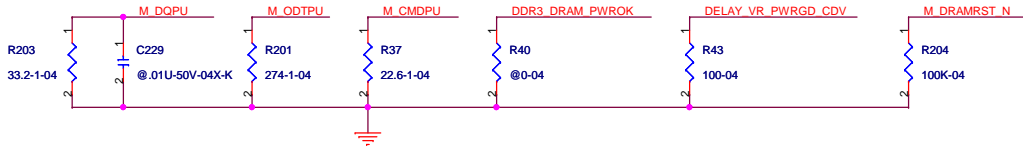

ELITEGROUP
Project : ES10ISx

Size	Document Number	Rev
	CPU CEDARVIEW-3/4	A
Date:	Sunday, February 13, 2011	Sheet 6 of 34

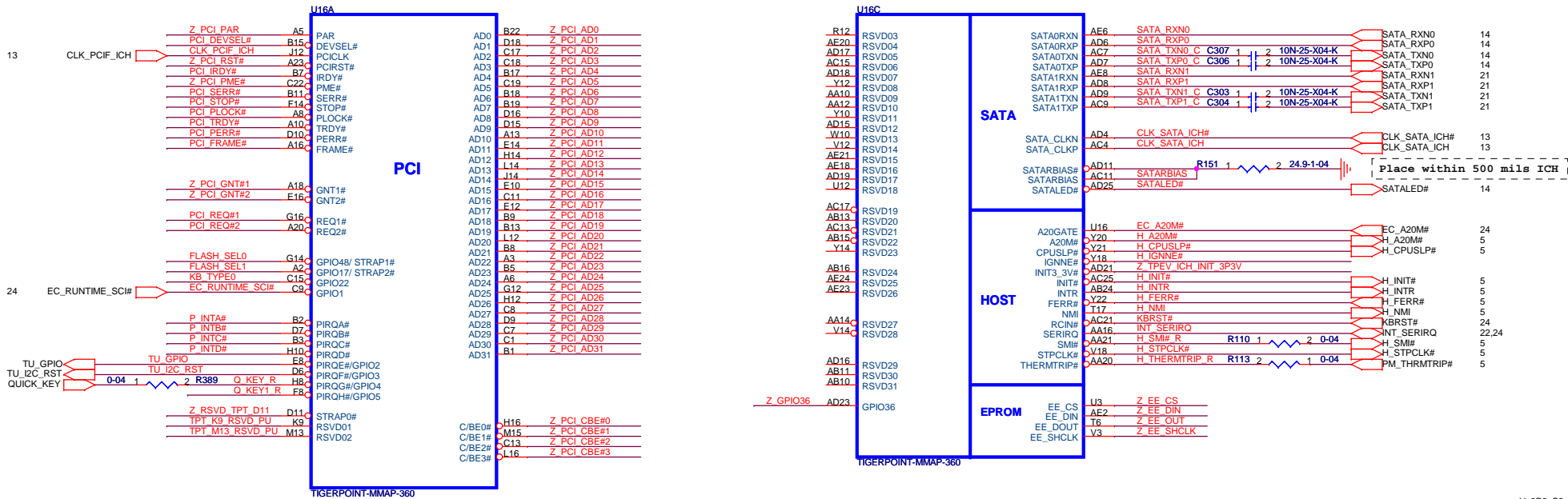

Place within 500 mils ICH

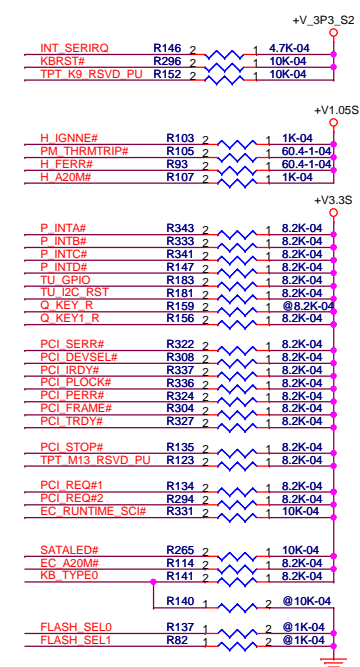

Design Note : TPT_GPIO22(KB_TYPE0) Stuff for validating CK505 driving DPLL GPIO reserved for DPLL REF CLOCK selection

	FLASH_SELO	FLASH_SEL1
SPI	X	V
LPC	X	X
PCI	V	X

ELITEGROUP
Project : ES10ISx
 Size Document Number Rev A
SB TIGERPOINT 1/4
 Date: Sunday, February 13, 2011 Sheet 8 of 34

USB	0	1	2	3	4	5	6	7
DEVICE	INT USB0	INTUSB1 SIM/BT	3G CARD	IO USB3	WLAN CARD	I2C	WEB CAM	CARD READER

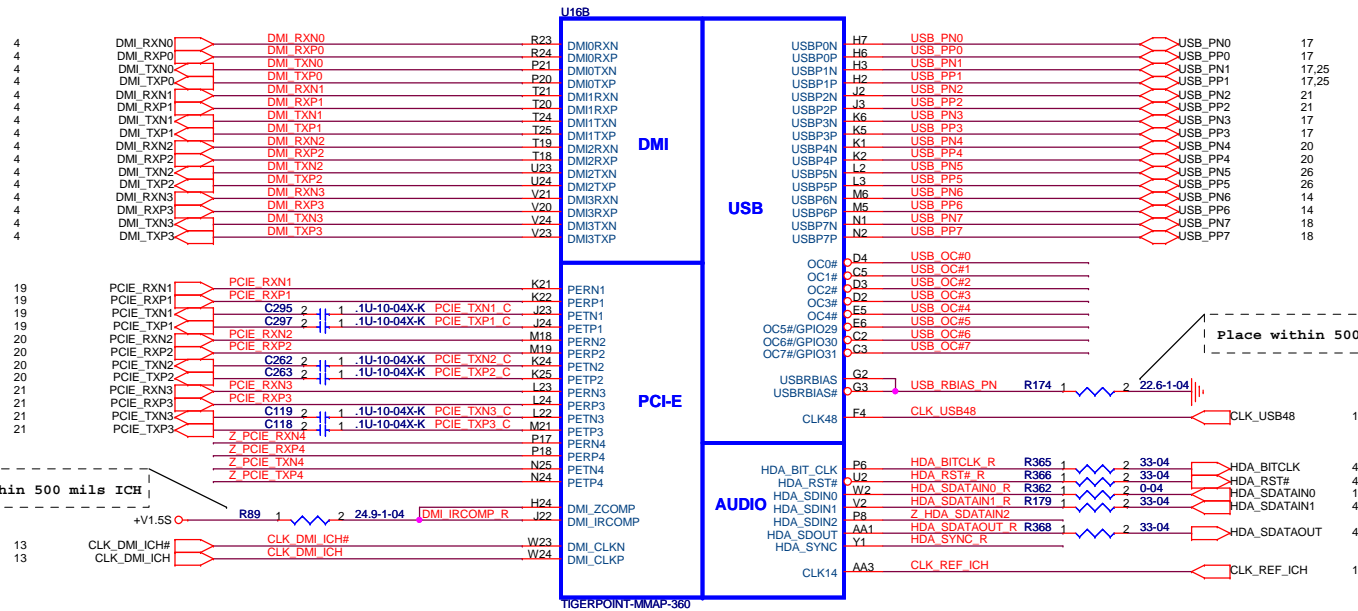

Place within 500 mils ICH

Place within 500 mils ICH

PCI-E	1	2	3	4
DEVICE	LAN	WLAN	3G	N/A

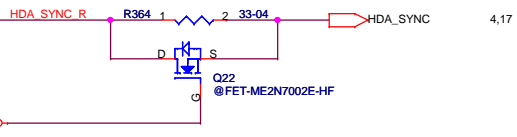

Audio	VA	VB
R364	V	X
Q22	X	V

HDA_SDATAOUT	PCI Express port config bit 1
HDA_SYNC	PCI Express port config bit 0

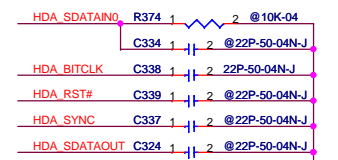
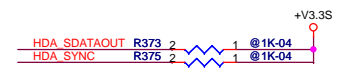
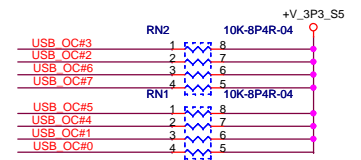

ELITEGROUP

Project : ES10ISx

Size	Document Number	Rev
	SB TIGERPOINT 2/4	A

Date: Sunday, February 13, 2011 Sheet 9 of 34

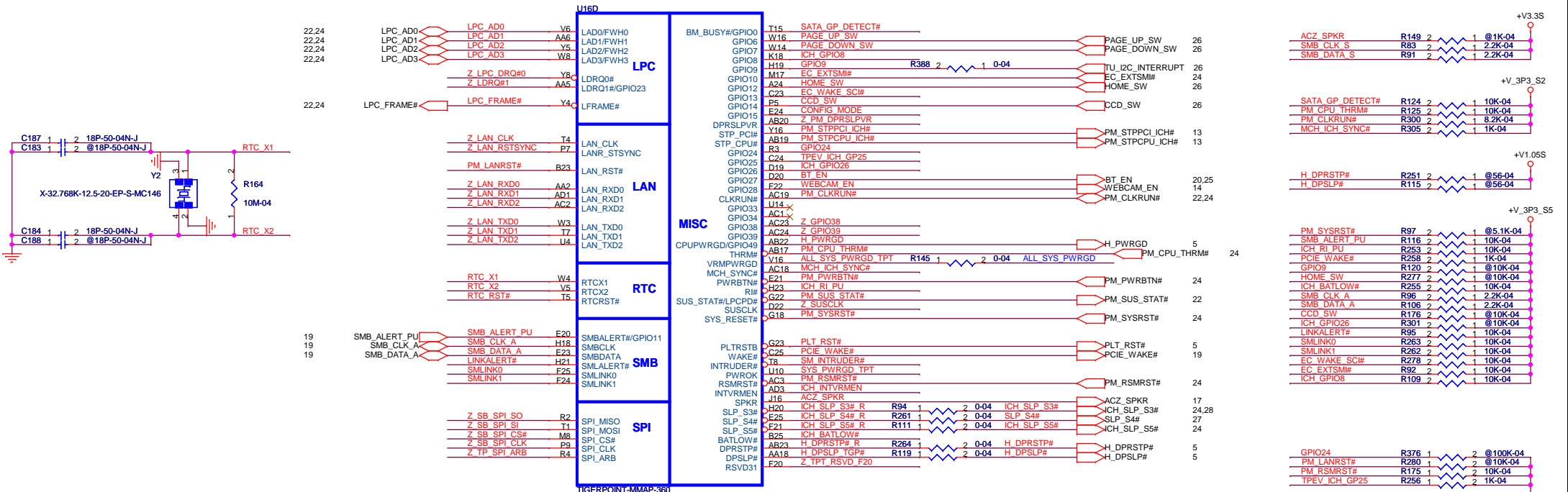

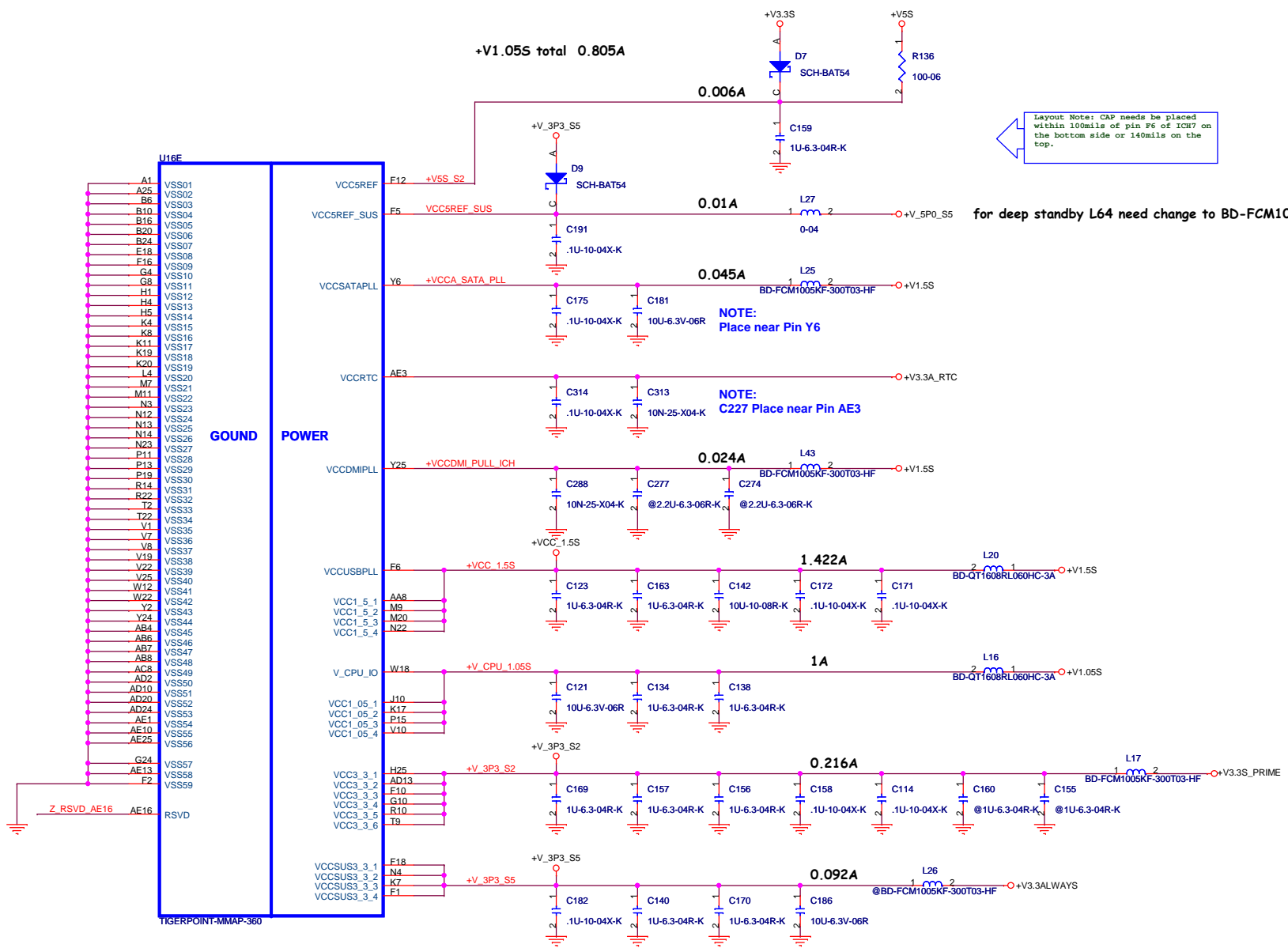

Layout Note: CAP needs be placed within 100mils of pin F6 of ICH7 on the bottom side or 140mils on the top.

for deep standby L64 need change to BD-FCM1005KF-300T03-HF

NOTE: Place near Pin Y6

NOTE: C227 Place near Pin AE3

GROUND POWER

ELITEGROUP
 Project : ES10ISx

Size	Document Number	Rev
	SB TIGERPOINT 4/4	A
Date:	Sunday, February 13, 2011	Sheet 11 of 34

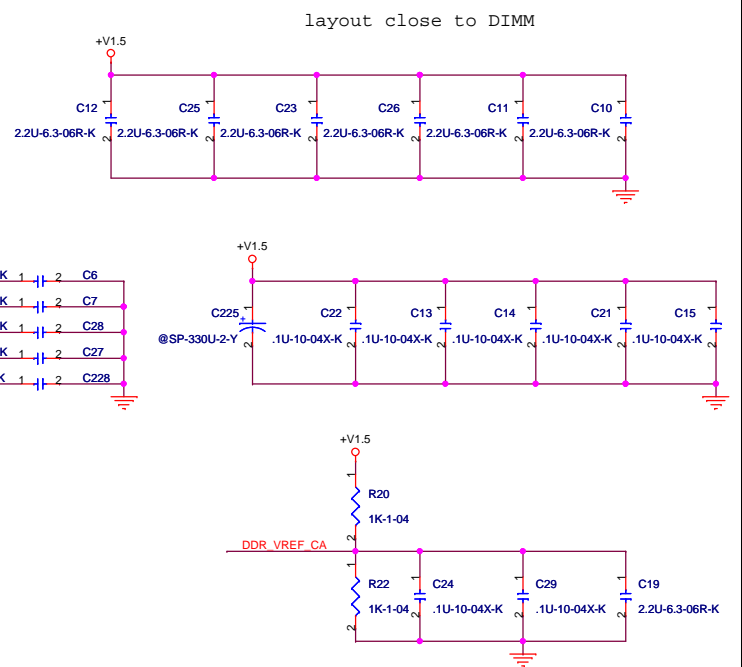
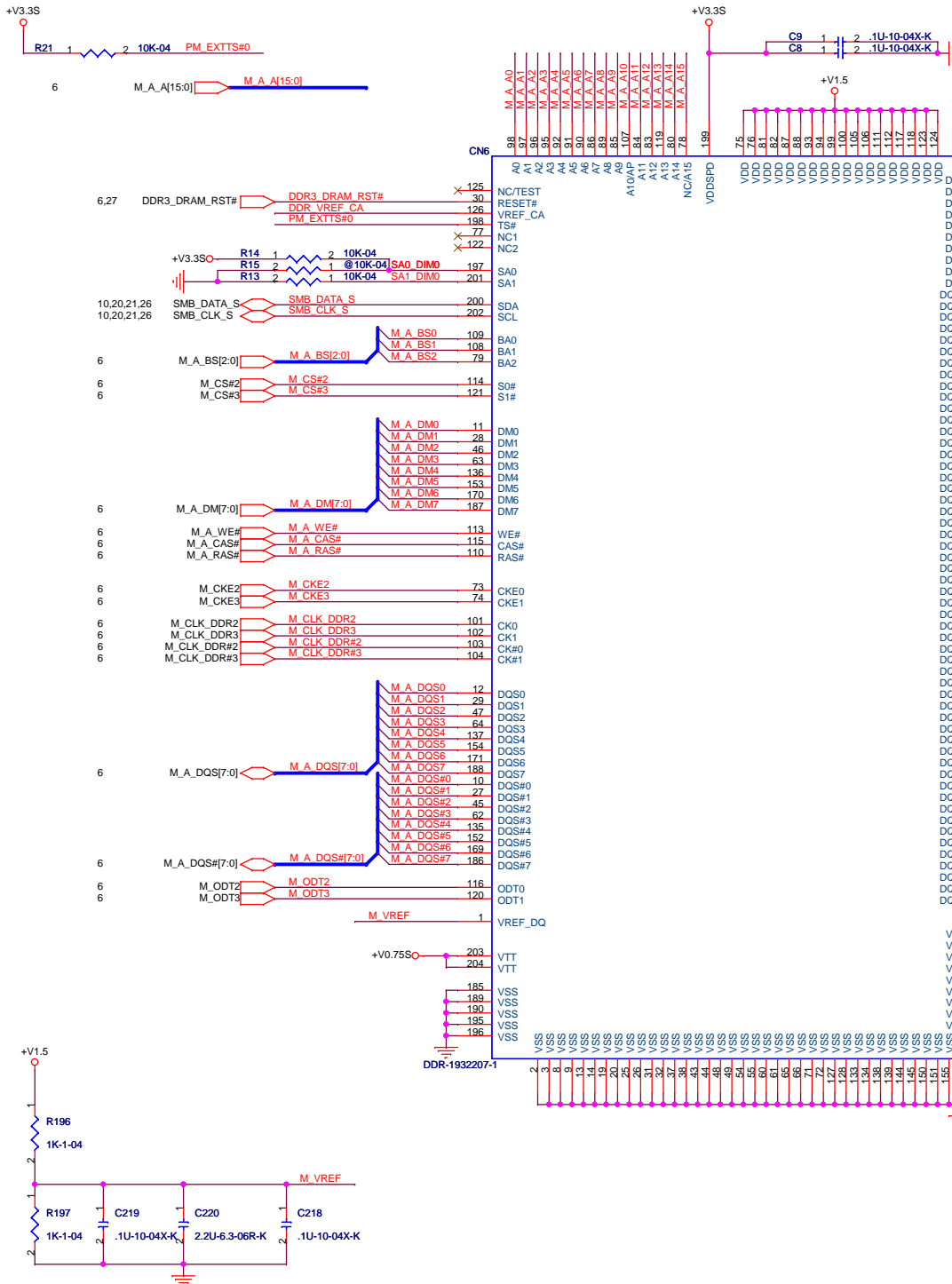

CLOCK GEN

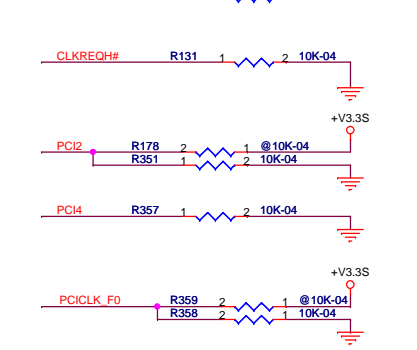
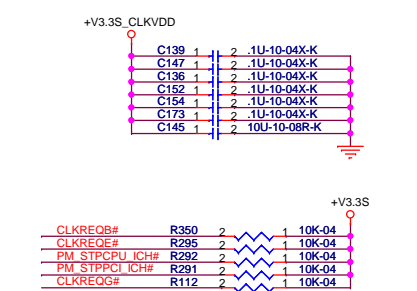
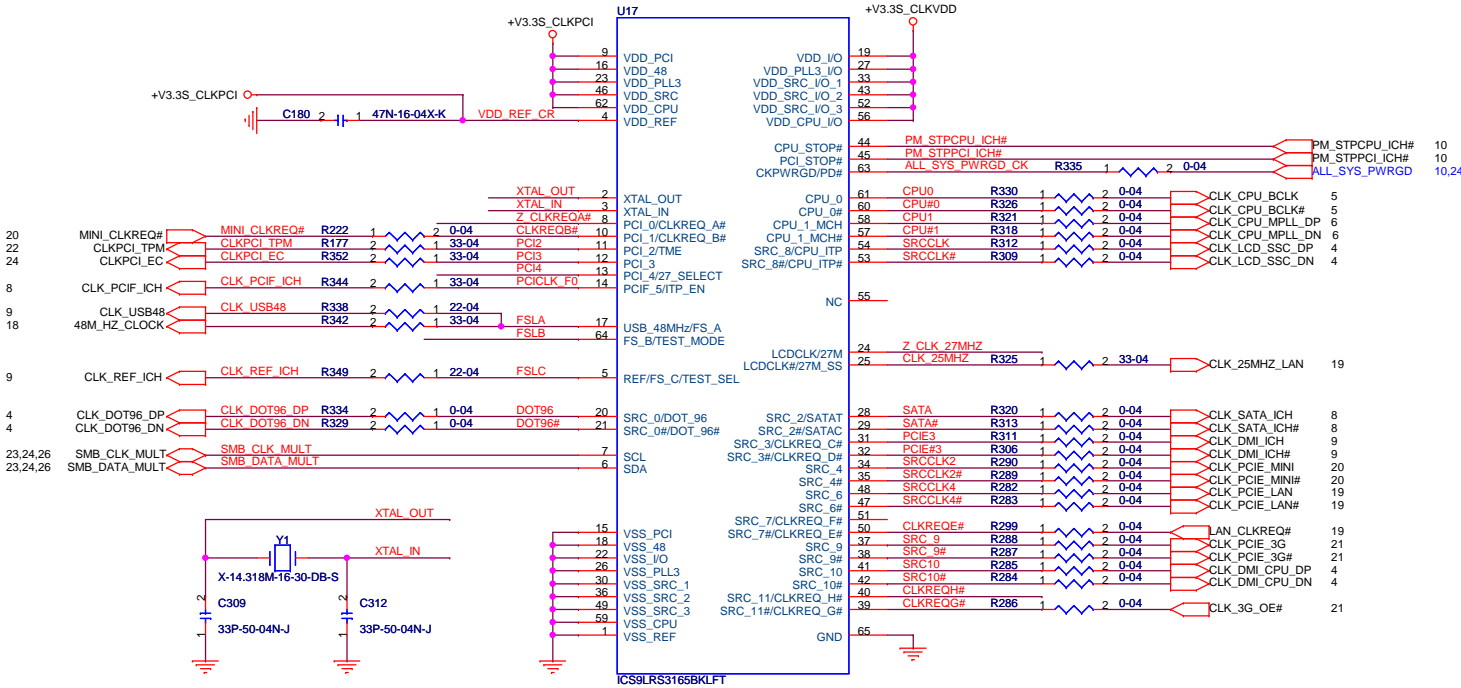
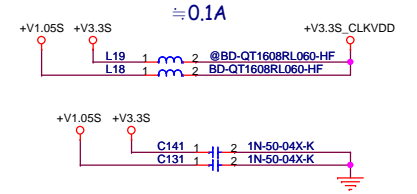
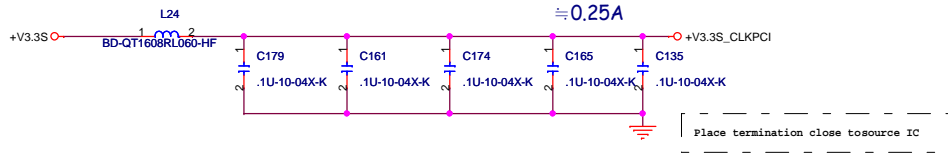

FSLC BSEL2	FSLB BSEL1	FSLA BSEL0	CPU	SRC	PCI
L	L	H	133MHz	100MHz	33MHz
L	H	L	200MHz	100MHz	33MHz
L	H	H	166MHz	100MHz	33MHz
H	L	H	100MHz	100MHz	33MHz
H	H	L	400MHz	100MHz	33MHz
H	L	L	333MHz	100MHz	33MHz
H	H	H	CPU SEL	100MHz	33MHz

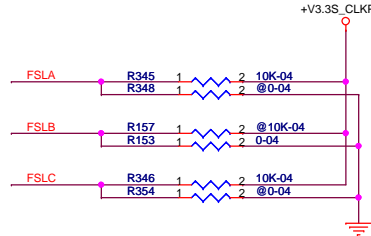

PS : CRB SETUP CPU Frequency 100MHz

Reserve for EMI

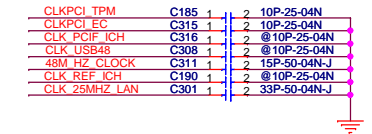

ELITE GROUP

Project : ES10ISx

Size	Document Number	Rev
	CLOCK GENERATOR	A

LCD+WEB 30 PIN CON

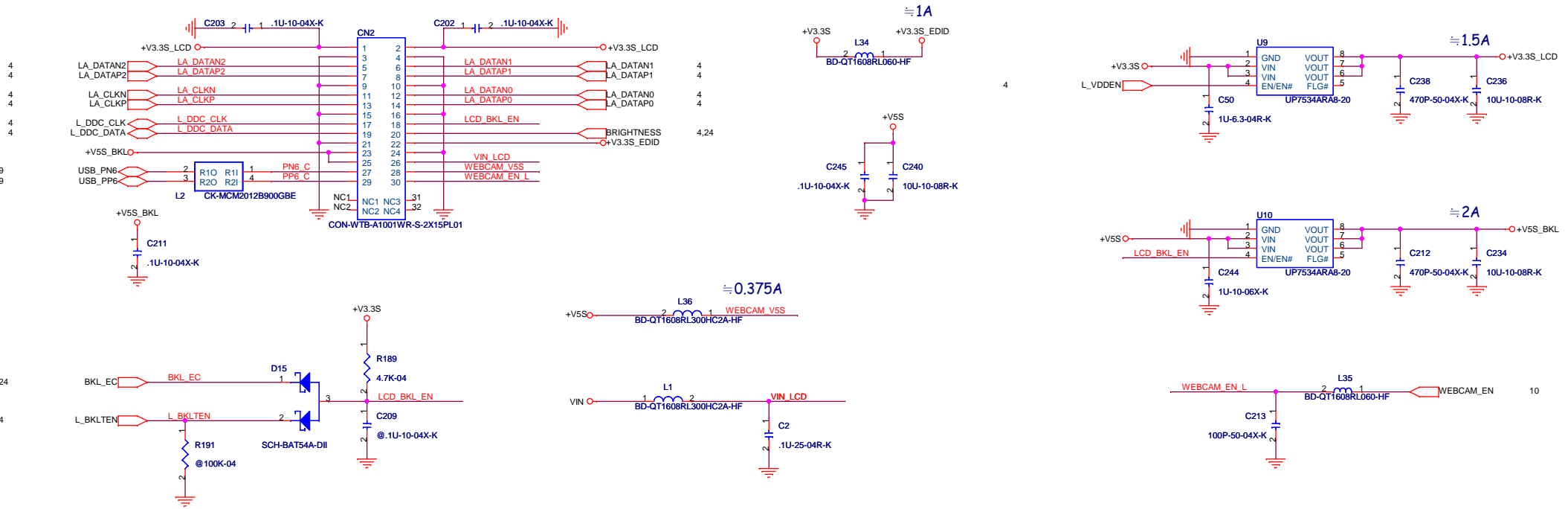

SATA HDD

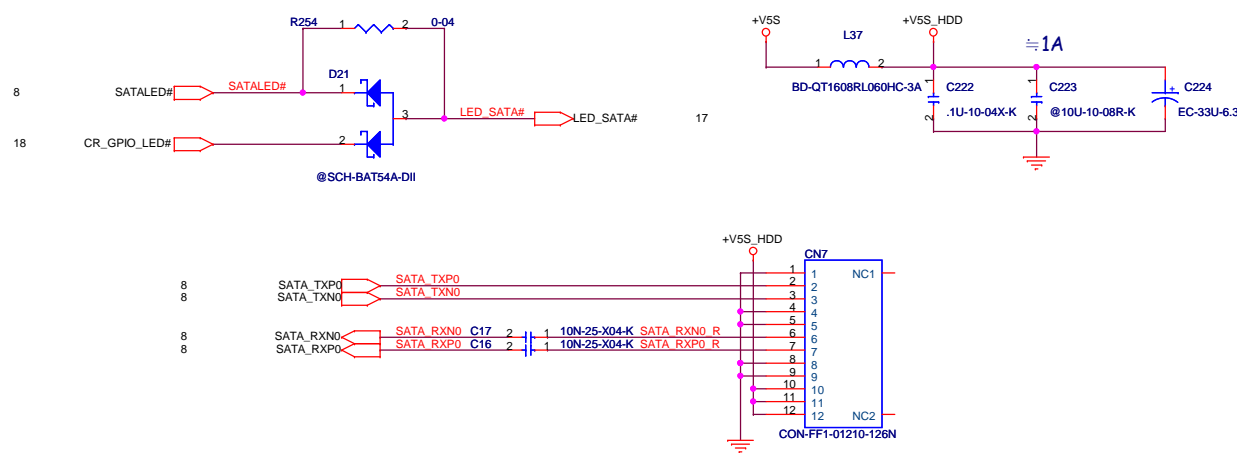

ELITEGROUP

Project : ES10ISx

Size	Document Number	Rev
	LCD /WEB CAM / SATA	A
Date:	Sunday, February 13, 2011	Sheet 14 of 34

CRT

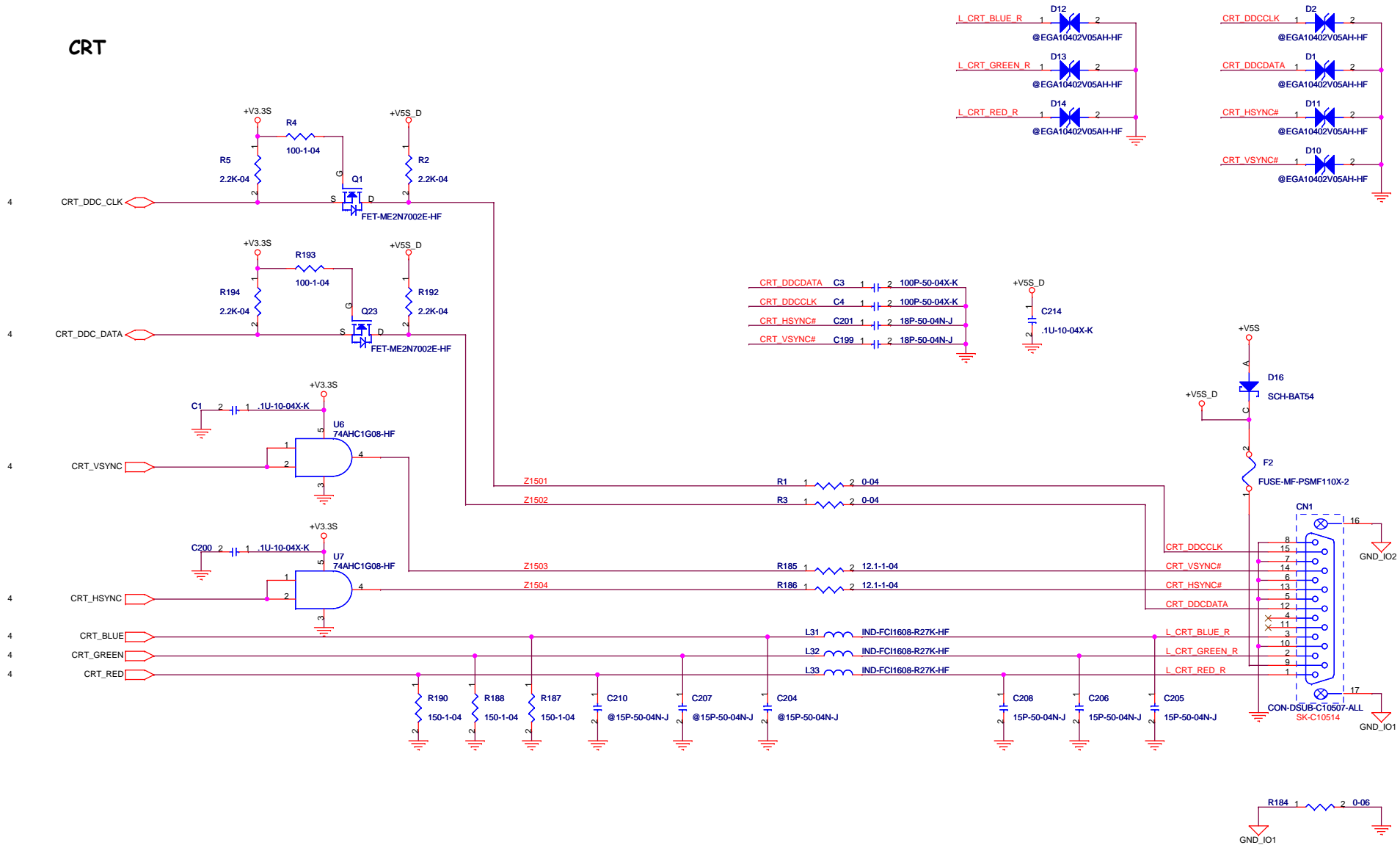

ELITEGROUP

Project : ES10ISx

Size	Document Number	Rev
	CRT CON	A

HDMI Cost Reduced Level Shifter

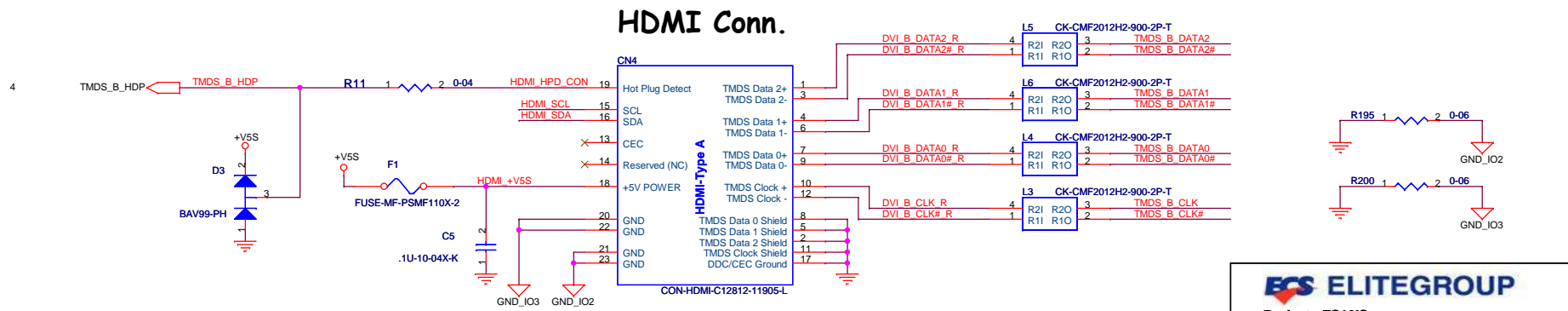
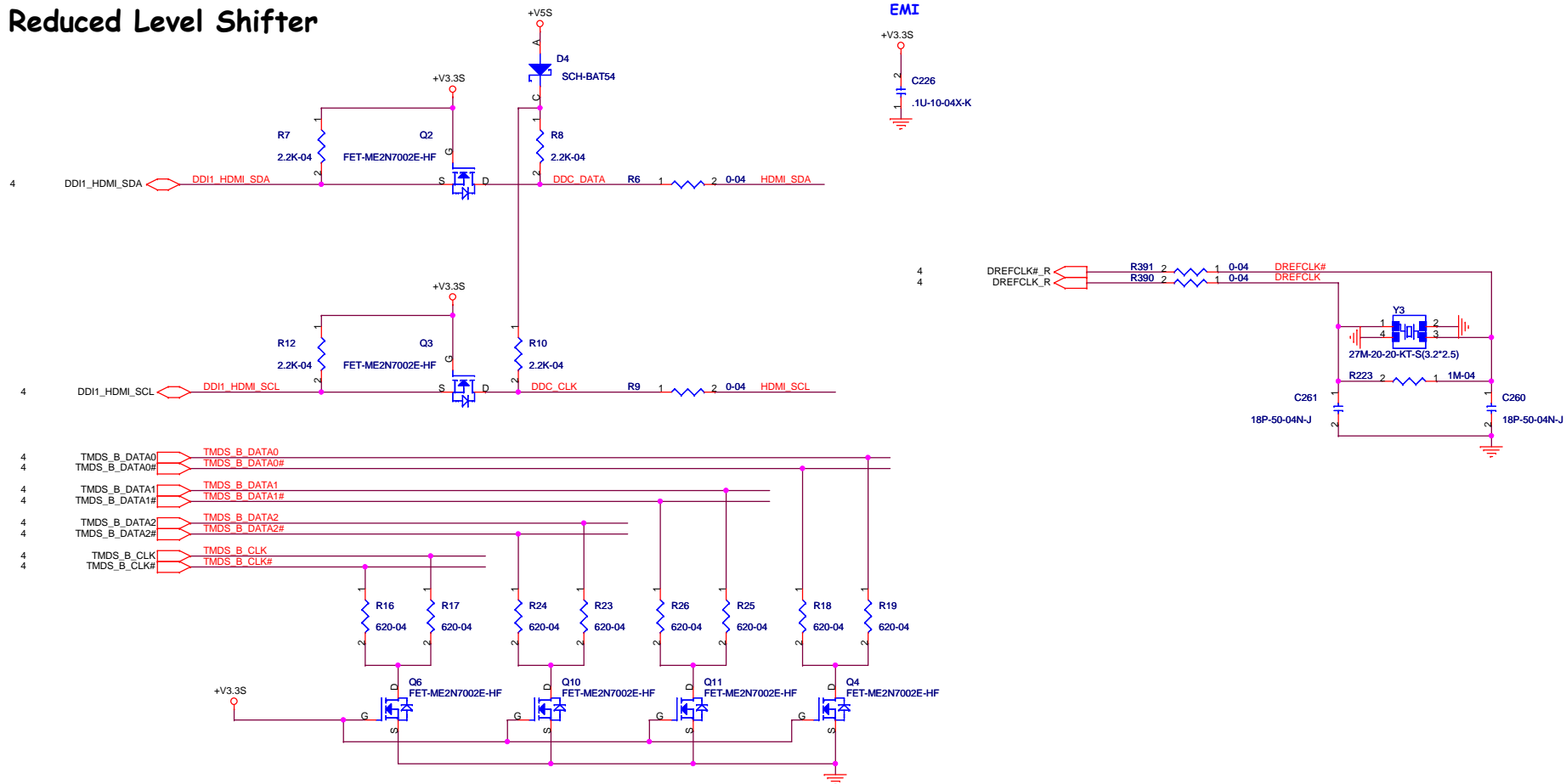

ELITEGROUP

Project : ES10ISx

Size	Document Number	Rev
	HDMI	A

Date: Sunday, February 13, 2011 Sheet 16 of 34

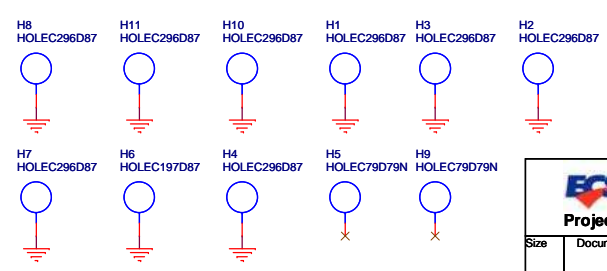
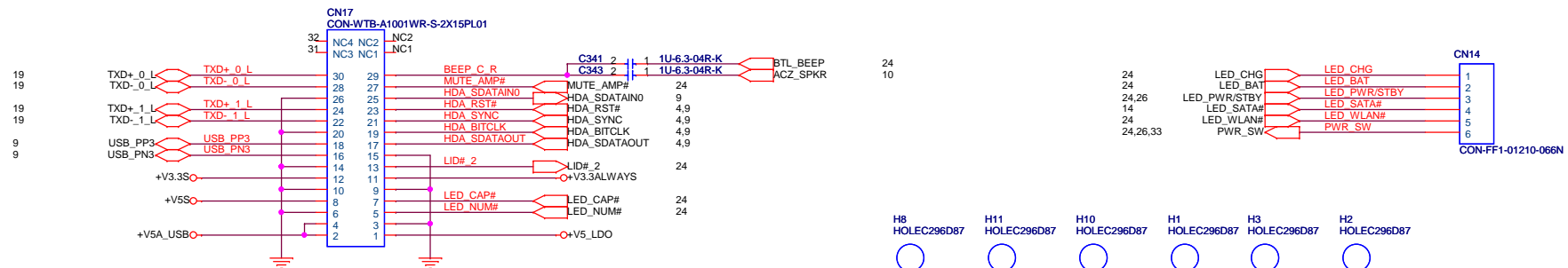
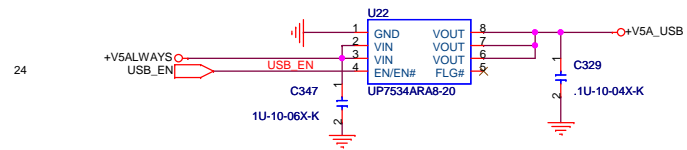
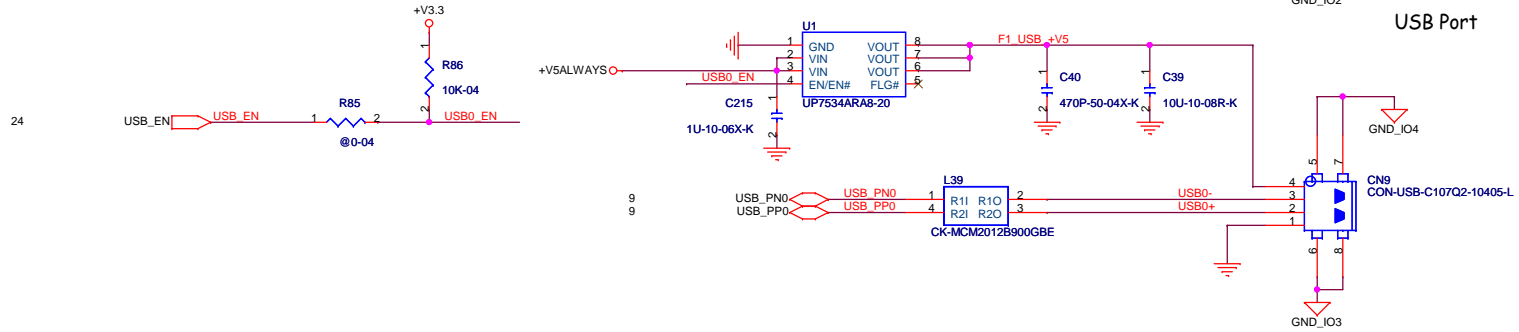
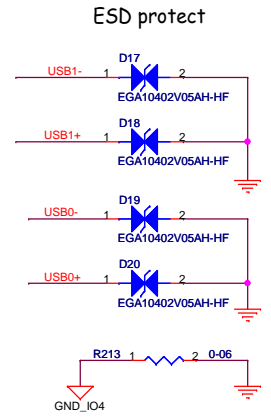
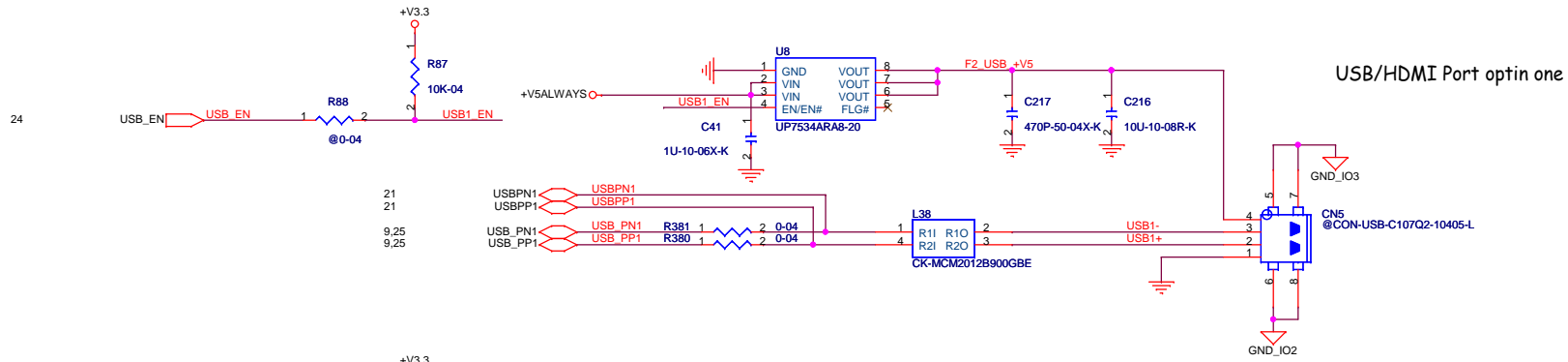

ELITEGROUP
 Project : ES10ISx

Size	Document Number	Rev
	USB & IO CON	A
Date:	Sunday, February 13, 2011	Sheet 17 of 34

CARD READER

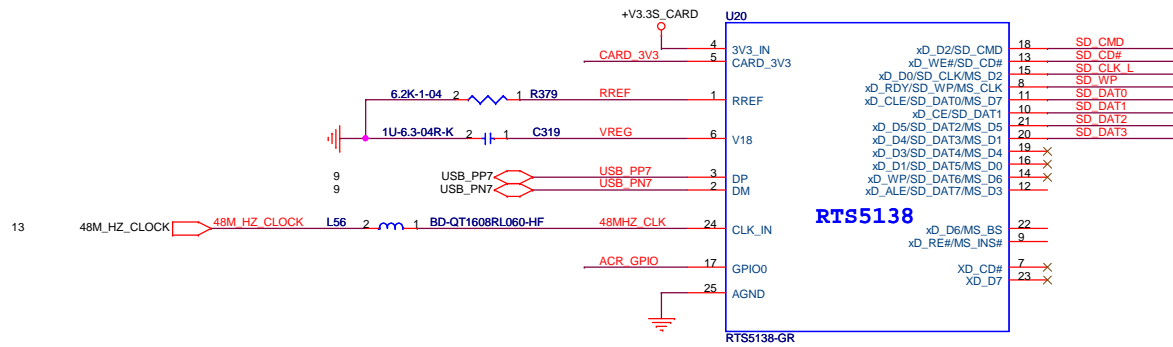

1. SD/MMC Card: 250mA

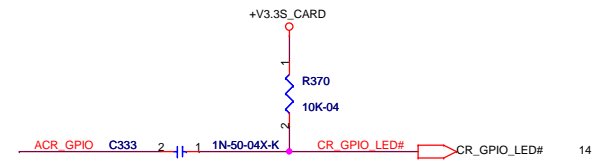
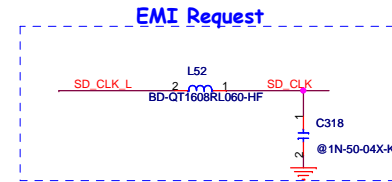
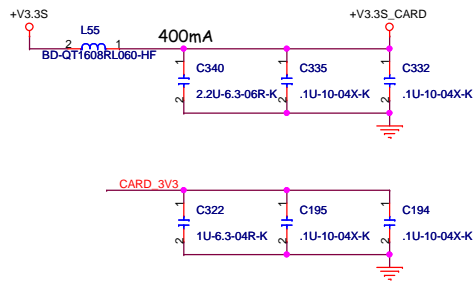
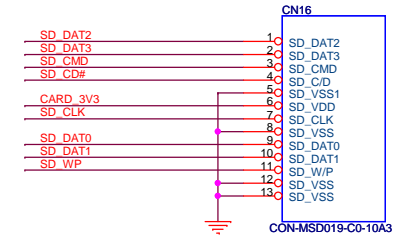

ECS ELITEGROUP

Project : ES10ISx

Size	Document Number	Rev
	CARD READER RST-5138	A
Date:	Sunday, February 13, 2011	Sheet 18 of 34

LAN

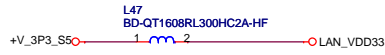

	8105E	8111E
C137	V	V
C113	V	V
C115	V	V
C128	V	V
C293	X	V
C129	X	V

	LDO	Swch
L23	X	V
C166	X	V
C164	X	V

	8105E	8111E
C116	V	V
C130	V	V
C126	V	V
C298	X	V
C302	X	V
C296	X	V
C151	X	V

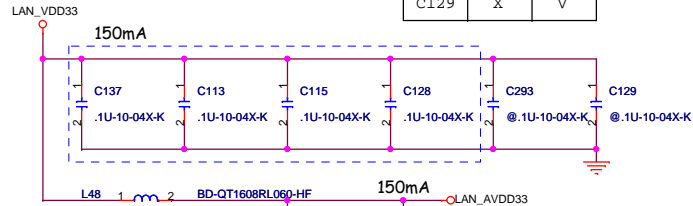

	LDO	Swch
L48	X	V
C292	X	V
C117	X	V

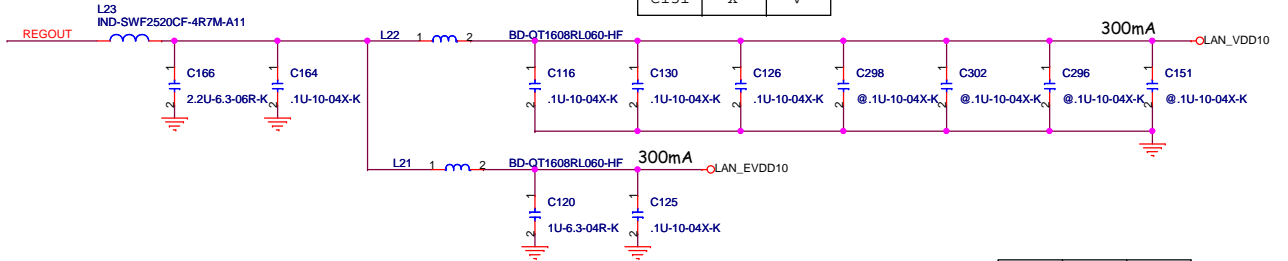

Swch	Enable	Disable
R99	V	X
R102	X	V

	8105E	8111E
R279	X	V
R315	X	V
R144	X	V
R316	X	V
R293	X	V
R317	X	V

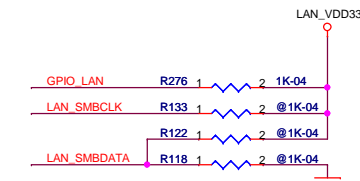
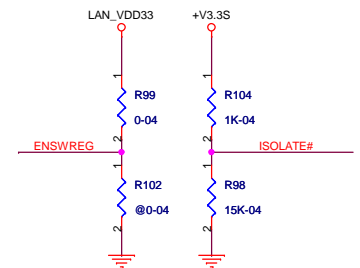
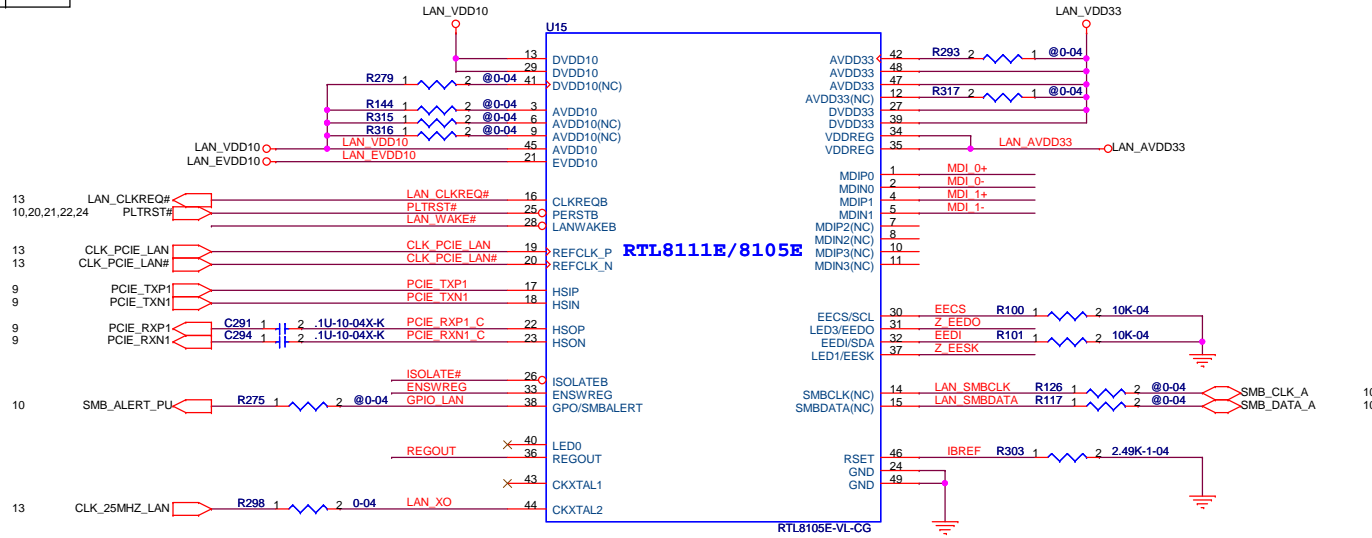

ASF	8105E	8111E
R118	X	X
R276	V	V
R113	X	V
R112	X	V

P.S : 8105E don't support ASF mode

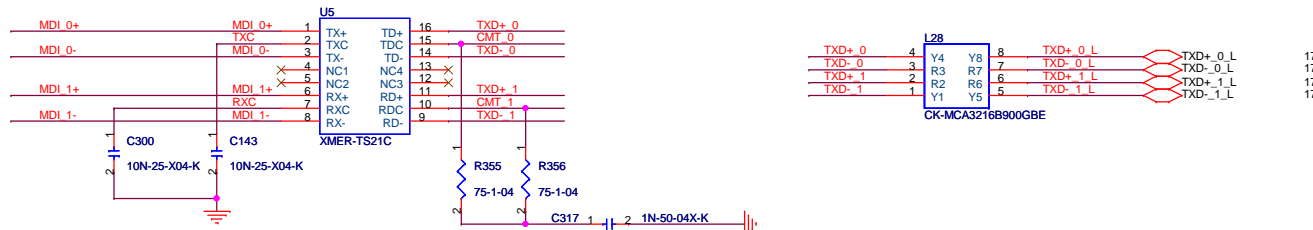

Project : ES10ISx

Size	Document Number	Rev
	LAN-RTL8111E/8105E-VL-CG	A

Date: Sunday, February 13, 2011 Sheet 19 of 34

Mini Card

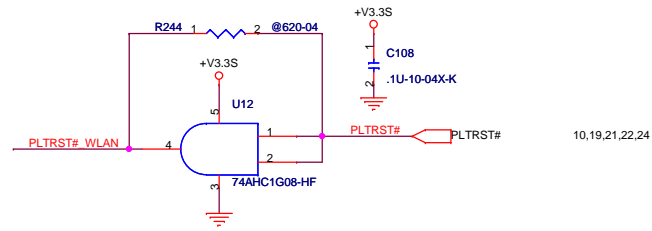
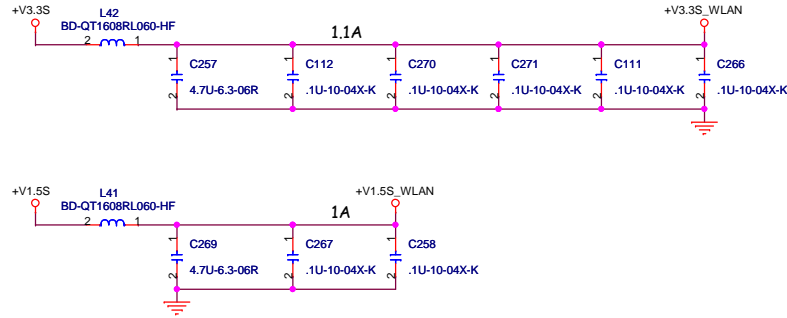
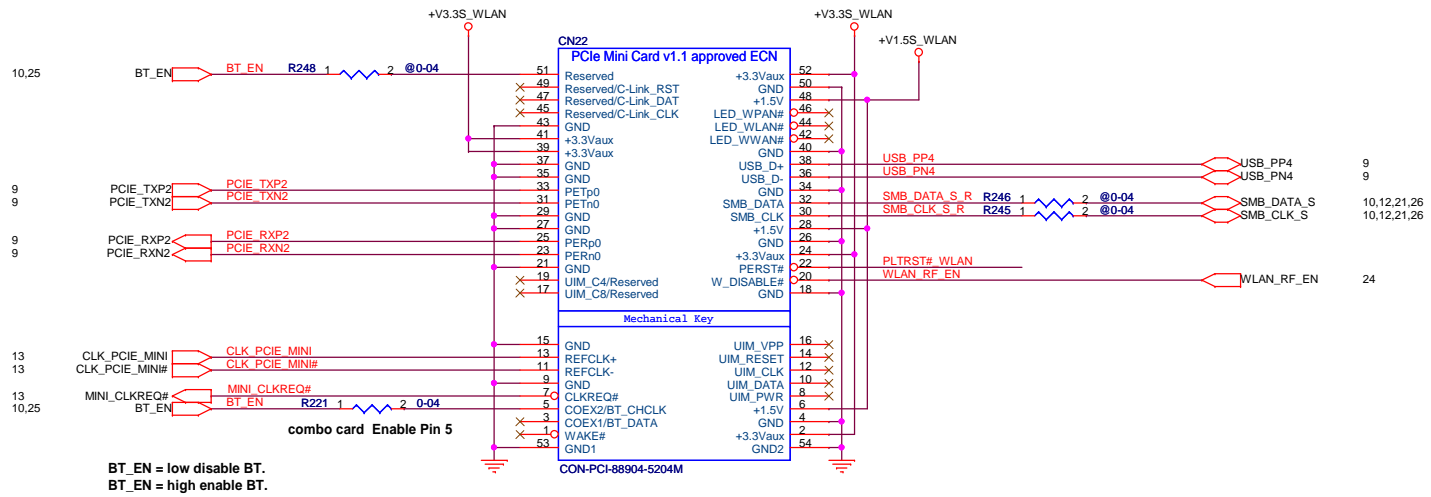

Mini Card_3G

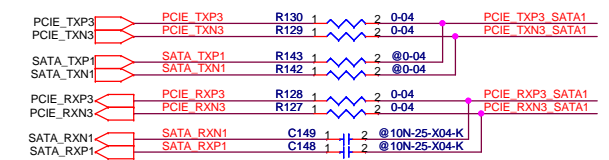
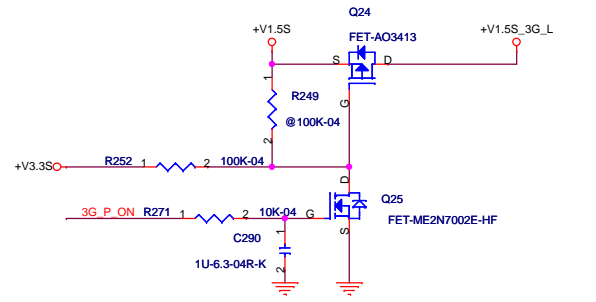
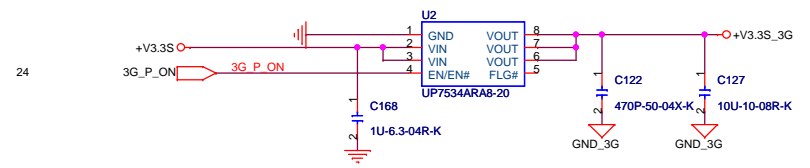
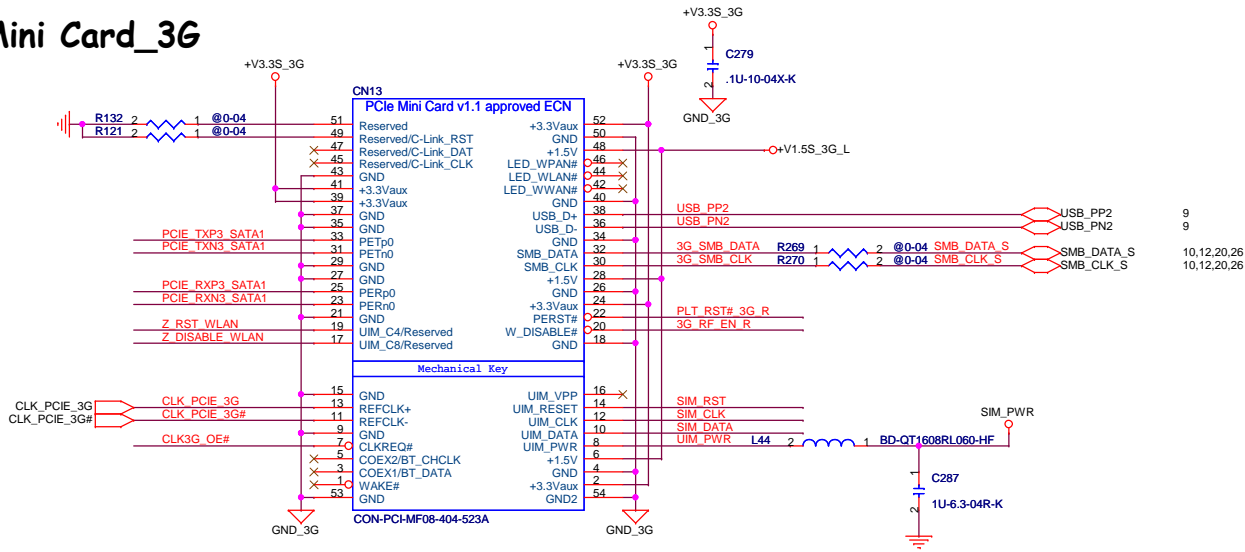

	PCI-E	M-SATA
R130	V	X
R129	V	X
R128	V	X
R127	V	X
R143	X	V
R142	X	V
C149	X	V
C148	X	V

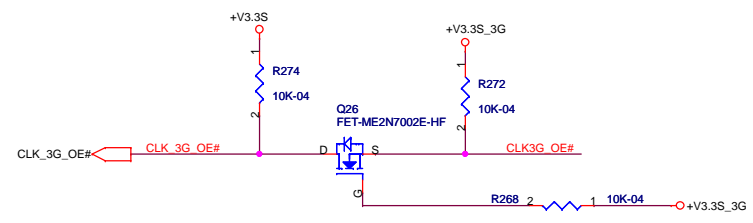
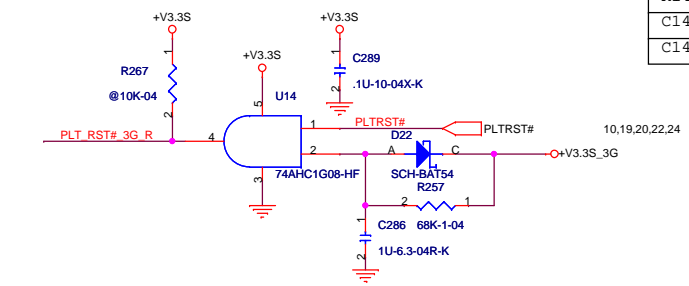

SIM_CARD

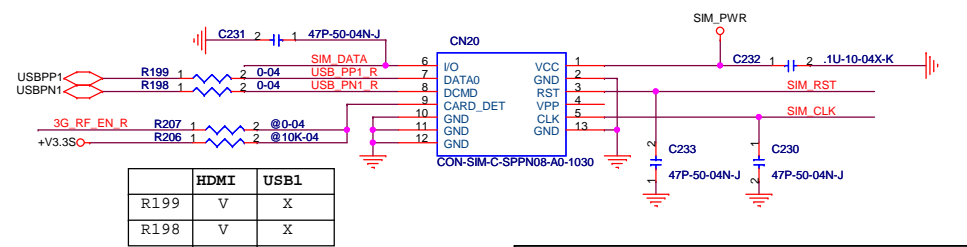
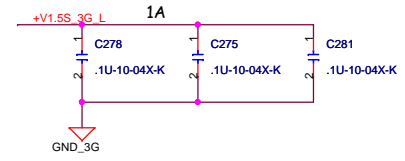
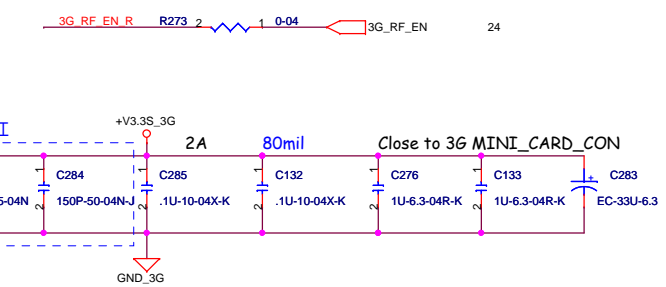

	HDMI	USB1
R199	V	X
R198	V	X

ELITEGROUP

Project : ES10ISx

Size Document Number 3G CON Rev A

Date: Sunday, February 13, 2011 Sheet 21 of 34

TPM

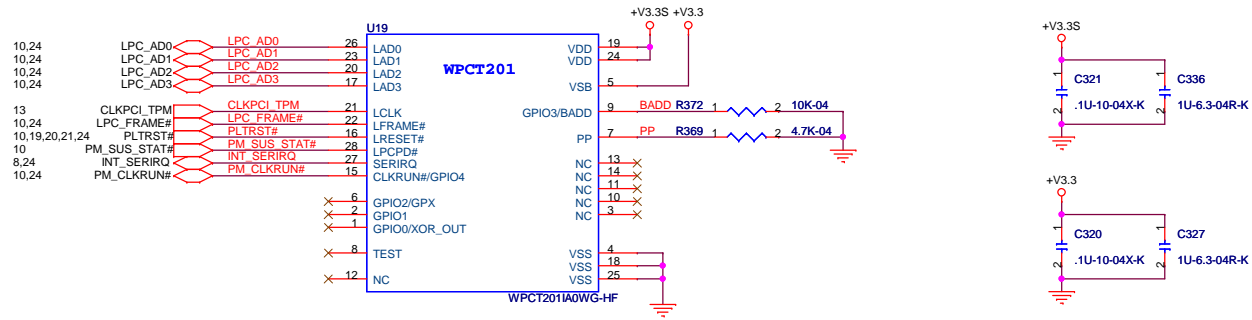

G-Sensor

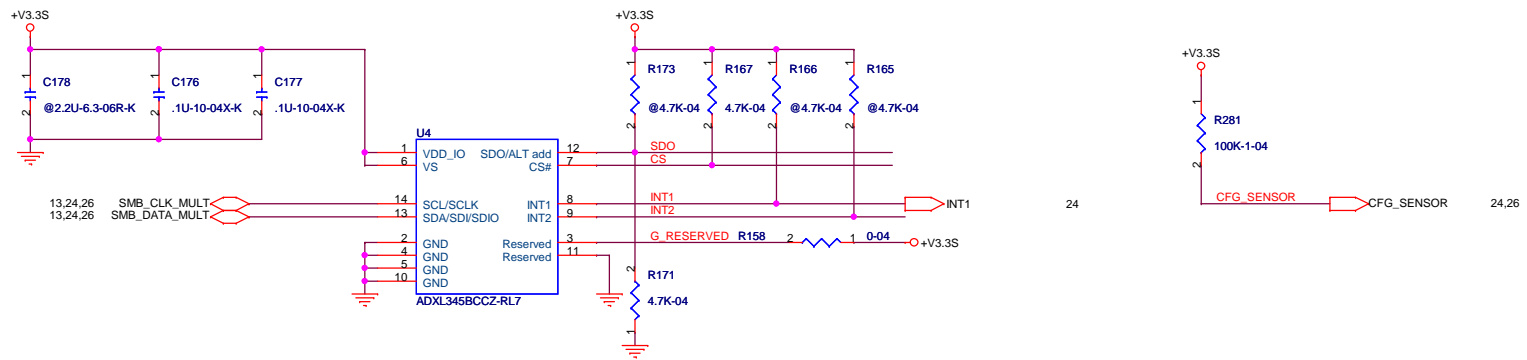

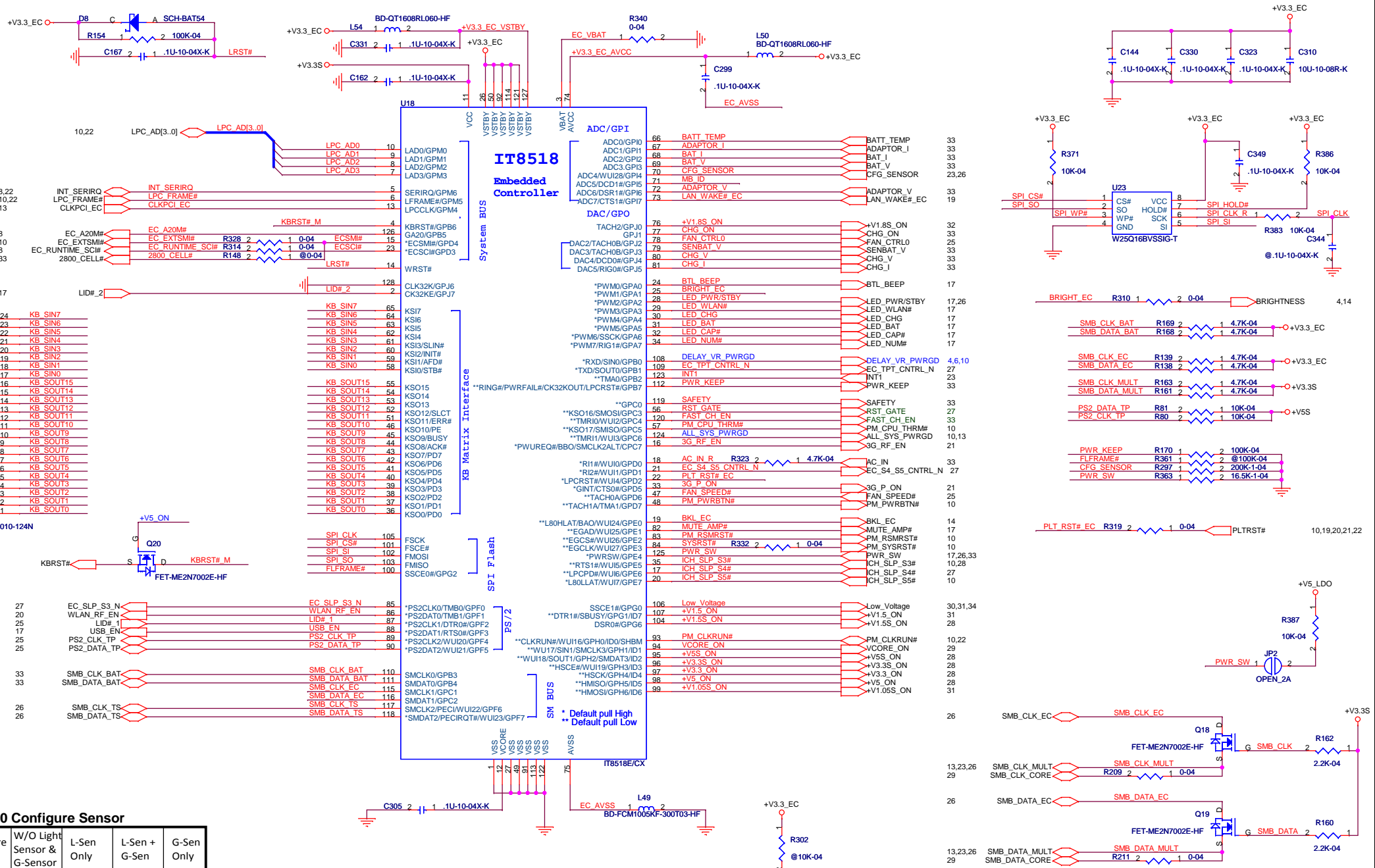

ES/EC10 Configure Sensor

Configure	W/O Light Sensor & G-Sensor	L-Sen Only	L-Sen + G-Sen	G-Sen Only
Voltage	0 V	0.825 V	1.65 V	2.2 V
R281	@	@	V	V
R297	V	V	V	V

ES/EC10 M/B revision ID---

MB rev. ID	Rev.A	Rev.A W/O TPM	Rev.B	Rev.B W/O TPM	Rev.C	Rev.C W/O TPM
MB_ID	0V	0.55V	1.05V	1.48V	1.98V	2.56V
R302	@	10K	10K	10K	10K	10K
R307	1.5K	2K	4.7K	8.2K	12K	34.8K

ELITEGROUP

Project : ES10ISx

Size	Document Number	Rev
	ES10ISX_MB_BD_REV_A	A

Date: Sunday, February 13, 2011 Sheet 24 of 34

FAN

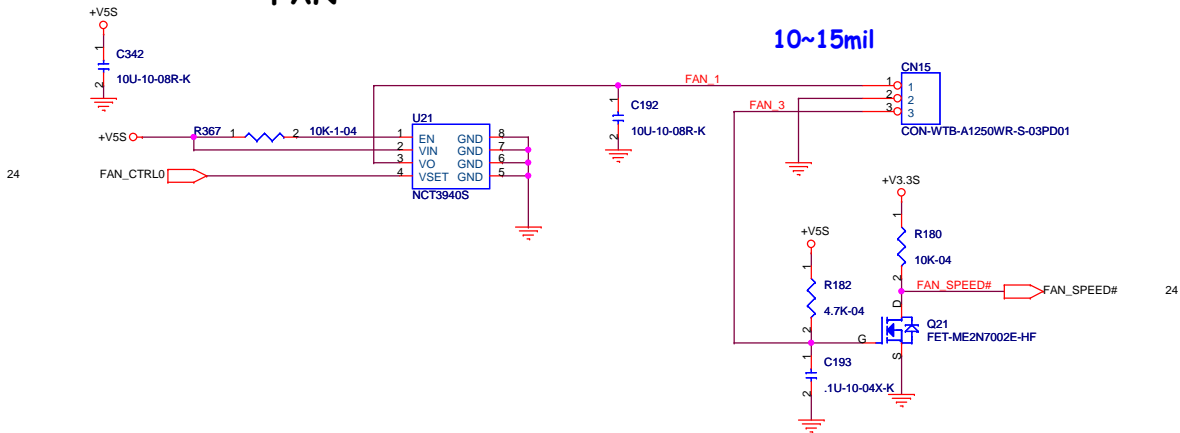

Touch PAD Button

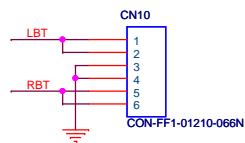

Touch PAD

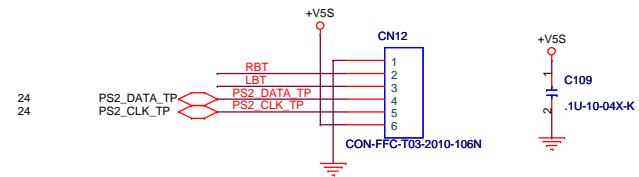

HALL Sensor

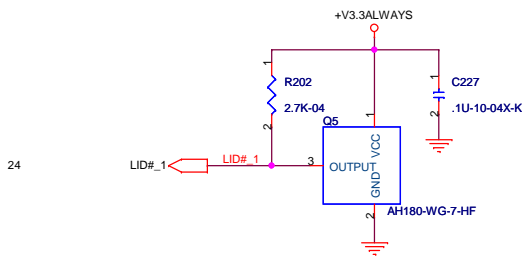

Option Bluetooth

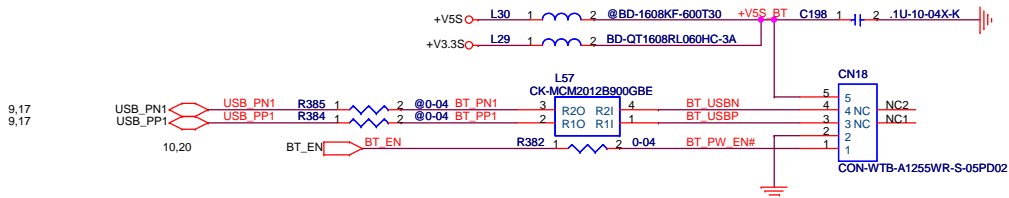

BT_EN = low disable BT.
BT_EN = high enable BT.

EMI Request

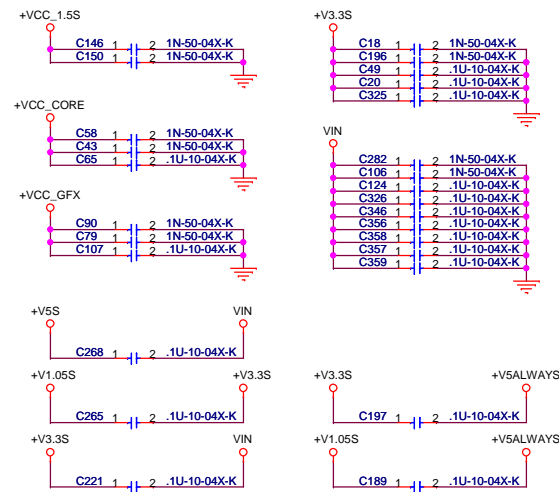

ELITEGROUP

Project : ES10ISx

Size	Document Number	Rev
	FAN/TP-B/BTH/LID/EMI	A

Date: Sunday, February 13, 2011 Sheet 25 of 34

For USB touch IC

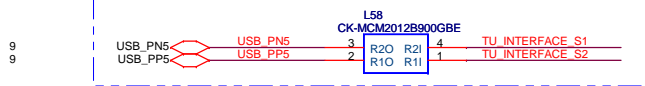

Trial Peak CON

For T/S BD

I2C touch IC For SB

EEPROM For EC

I2C touch IC For EC

LS Sensor For EC

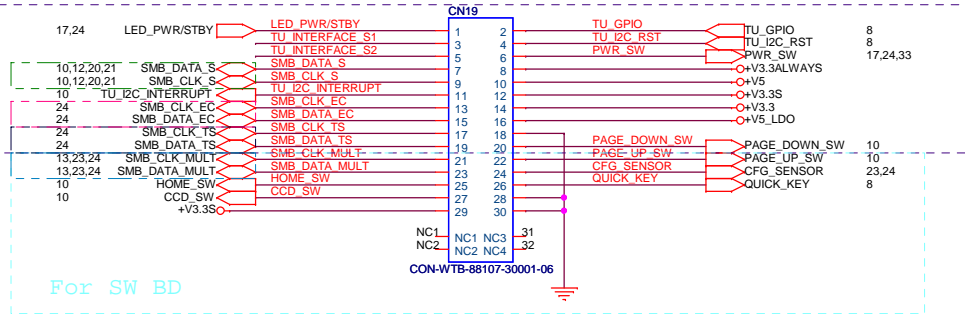

For SW BD

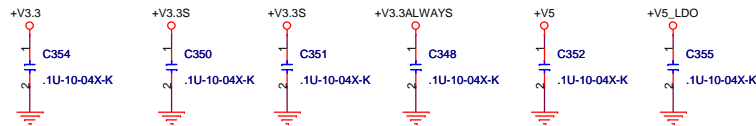

EC10 VS ES10 different

Item	For Trail Peak	For Stone Point
CN19	✓	X
CN8	X	✓
CN3	X	✓

Configure Sensor/Quick Key CON

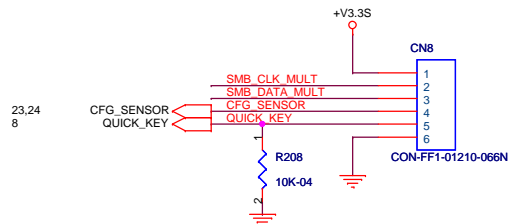

EEPROM CON

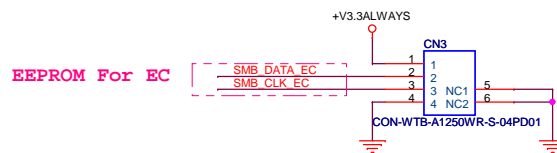

ECS ELITEGROUP

Project : ES10ISx

CDV DEEP STANDBY

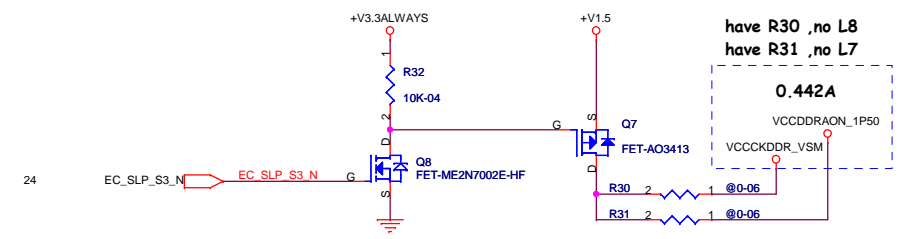
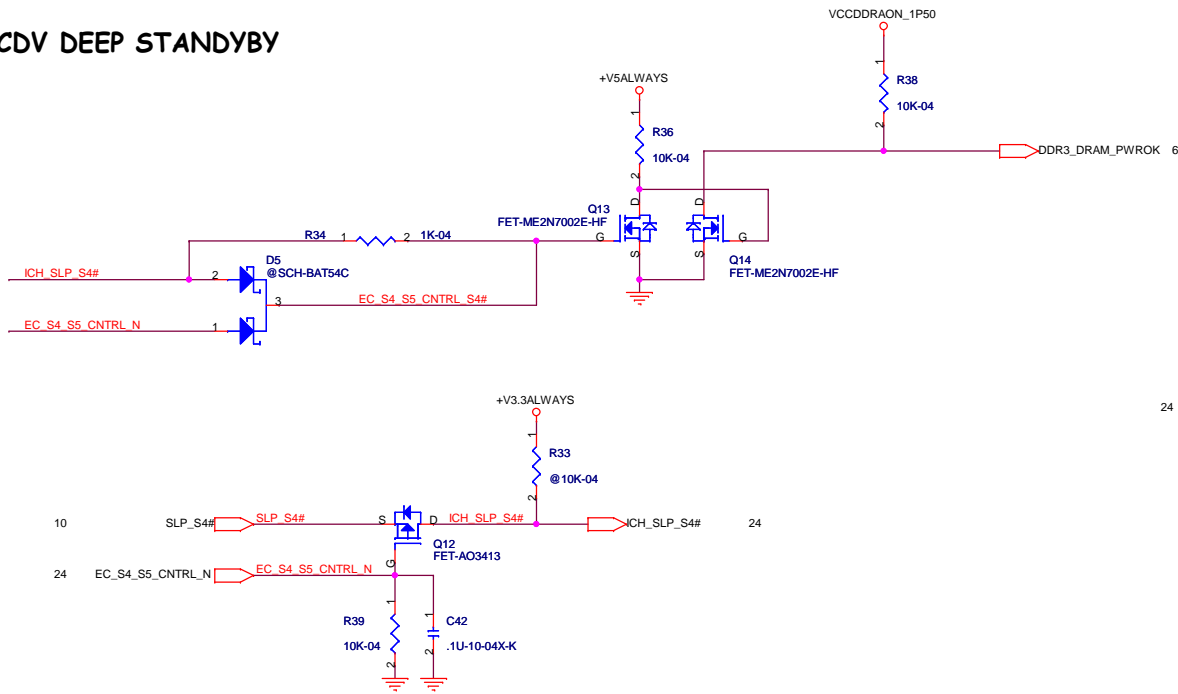

ICH DEEP STANDBY BY

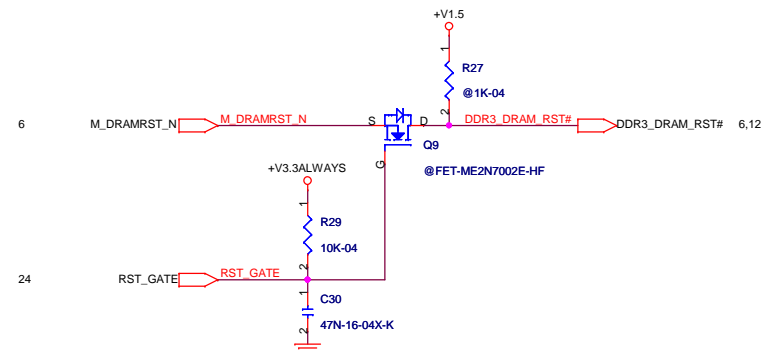
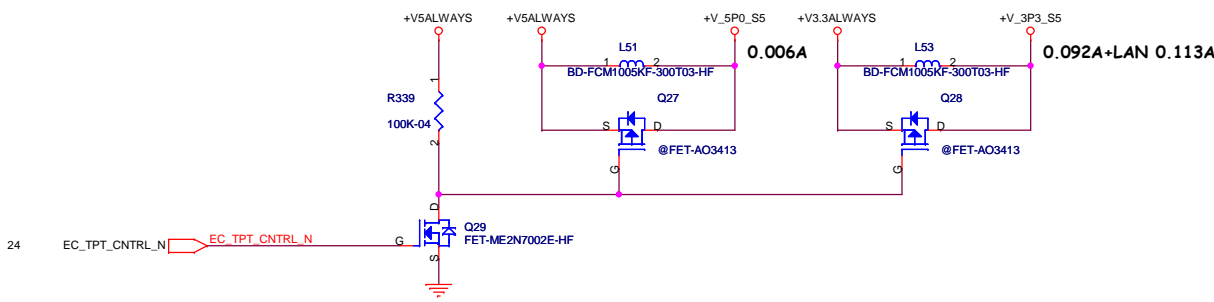

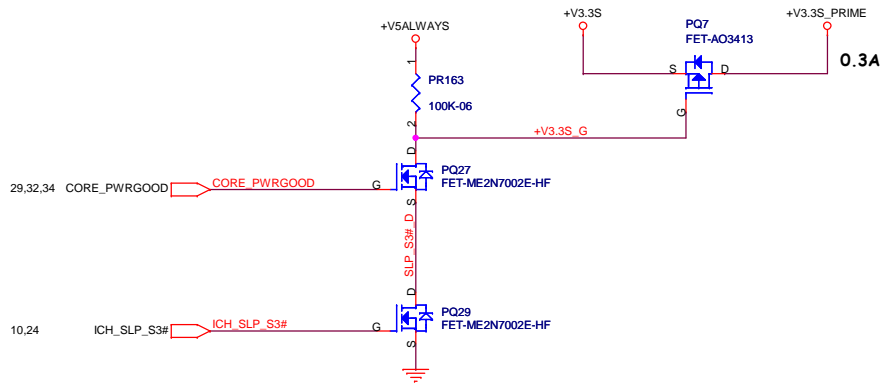
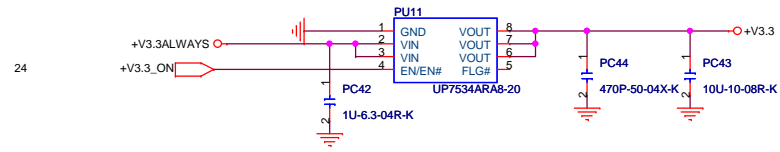
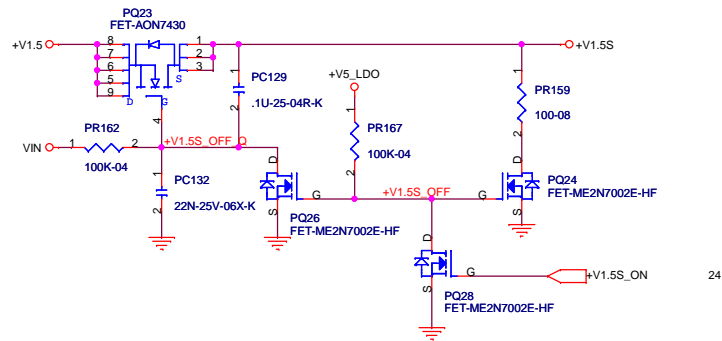
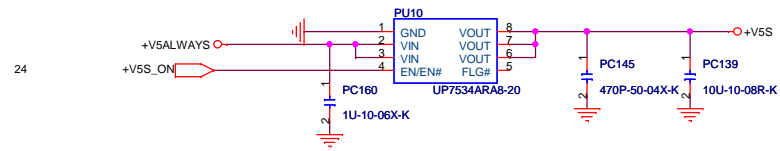
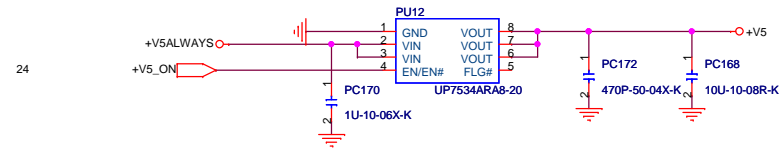
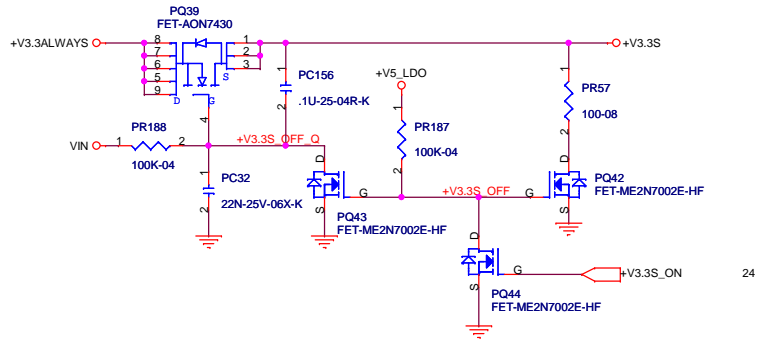

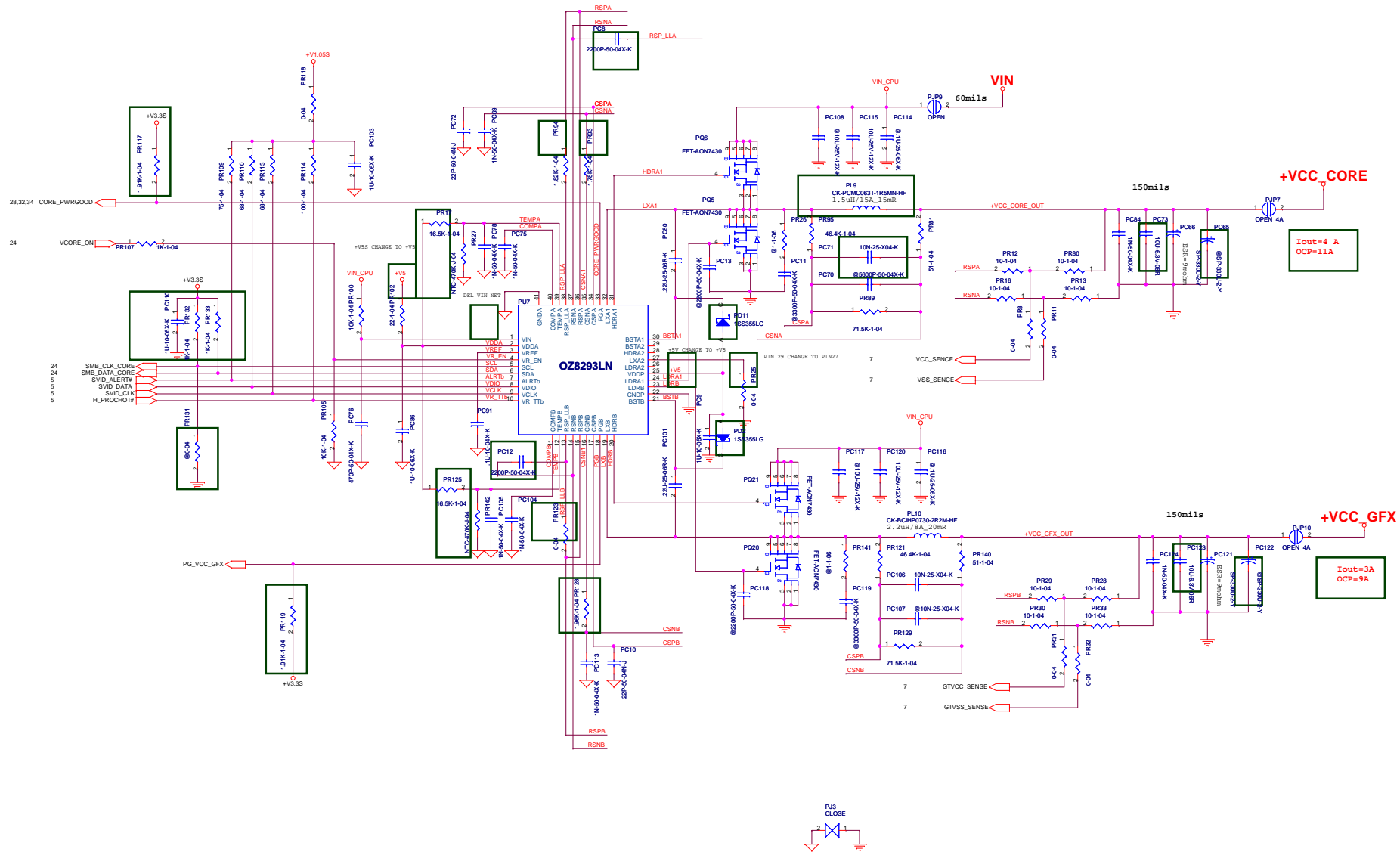

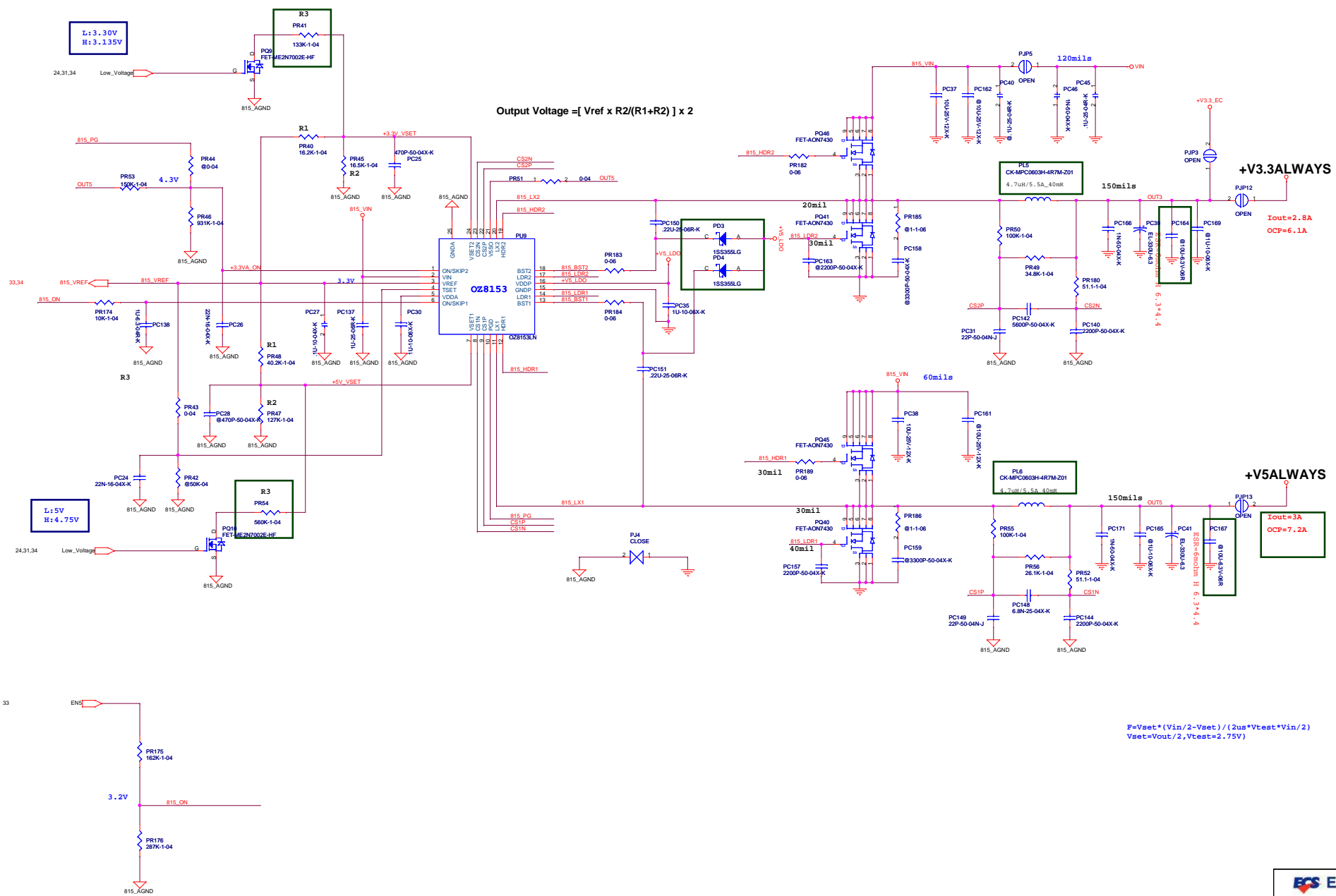

Output Voltage = [Vref x R2 / (R1+R2)] x 2

$$F = Vset * (Vin/2 - Vset) / (2us * Vtest * Vin/2)$$

$$Vset = Vout / 2, Vtest = 2.75V$$

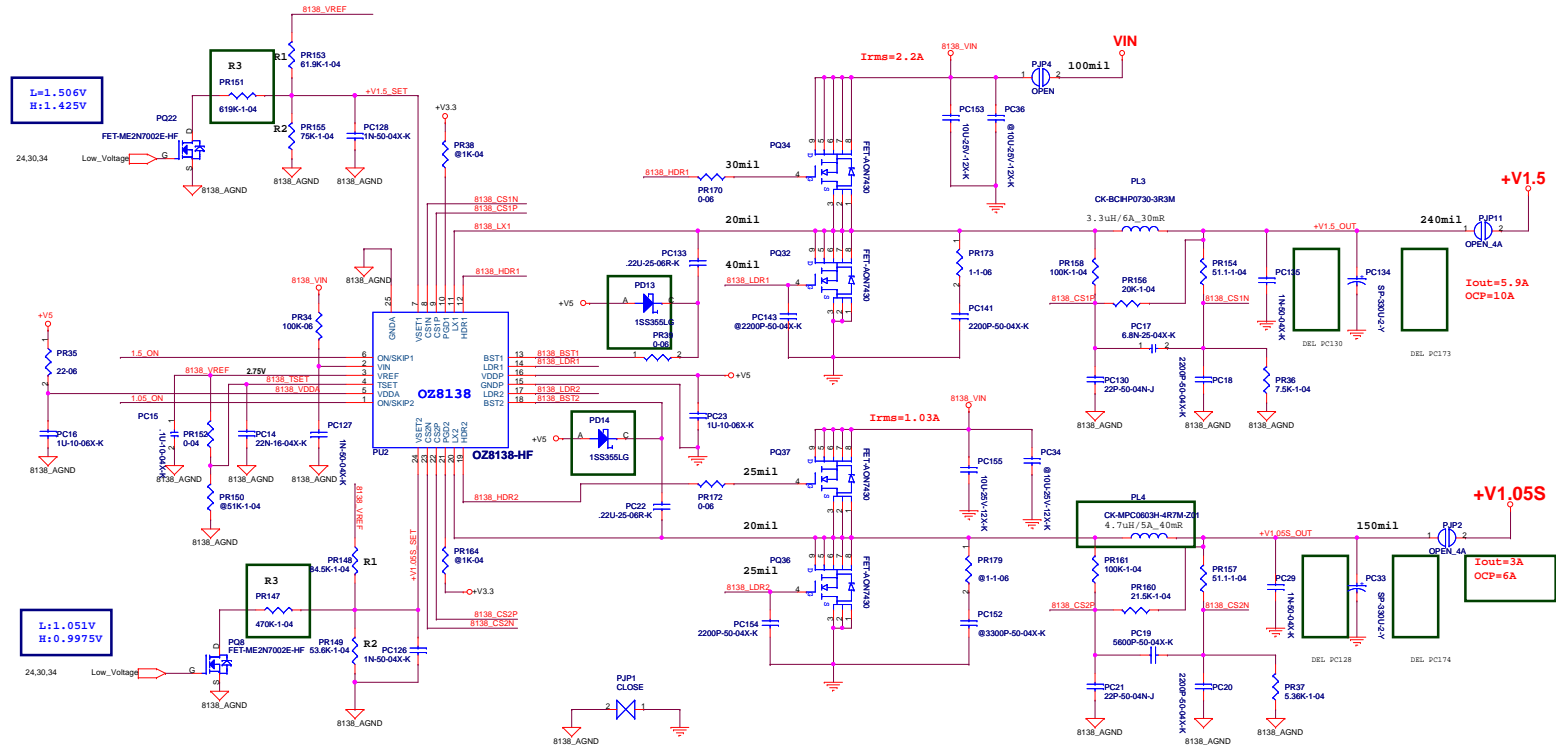

L=1.506V
H:1.425V

L:1.051V
H:0.9975V

$$P = V_{out} * (V_{in} - V_{out}) / (1.6 \mu s * V_{in} * V_{test})$$

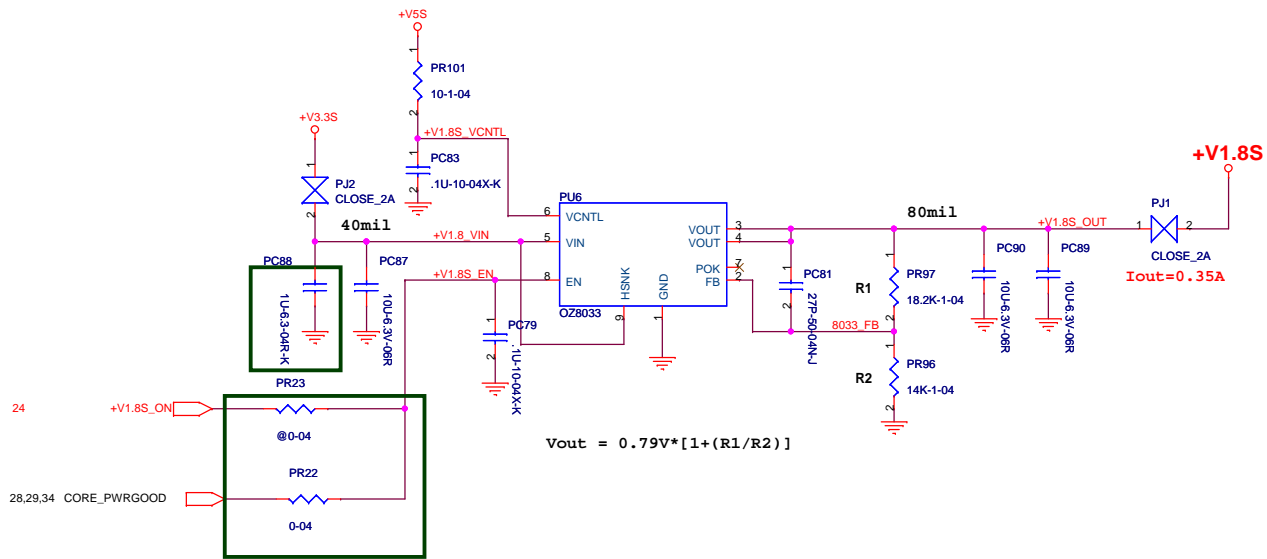
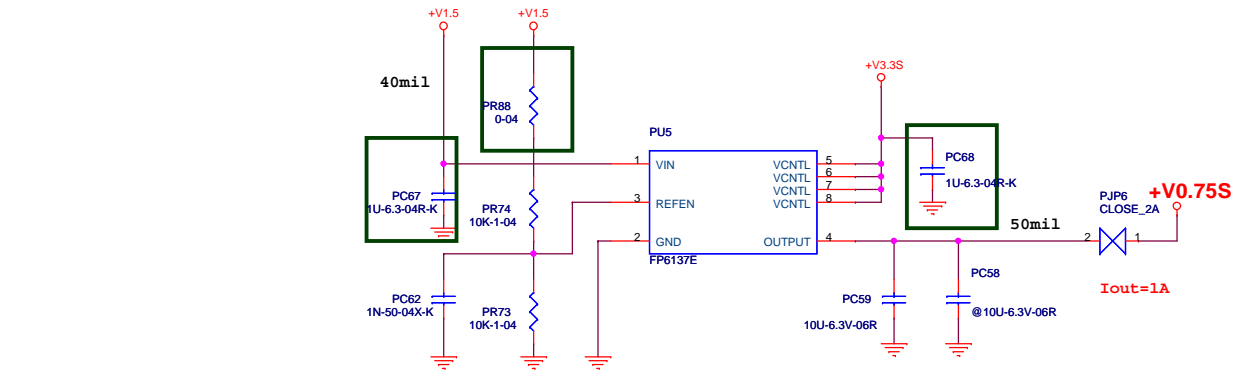

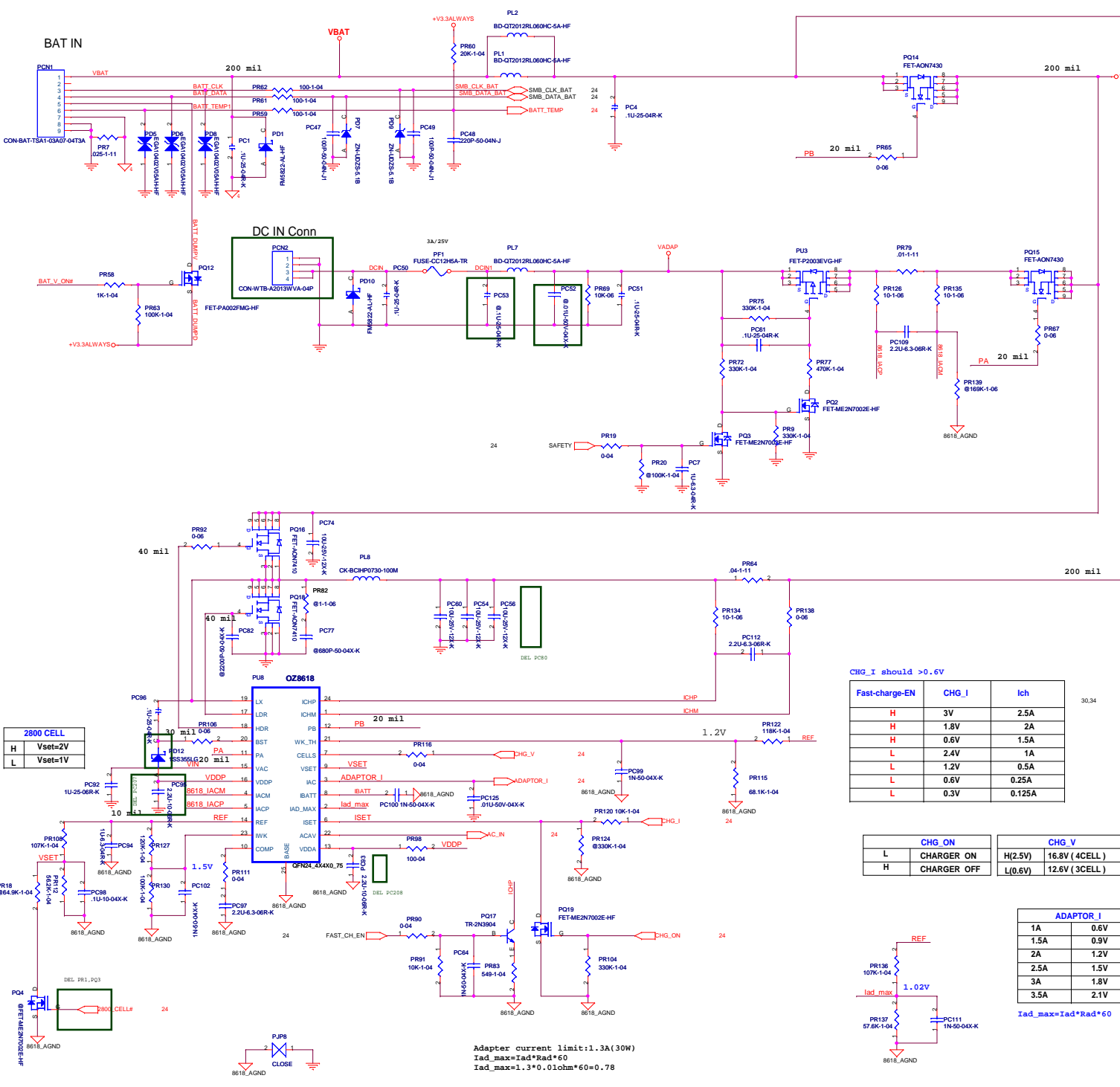

Battery Voltage Detect

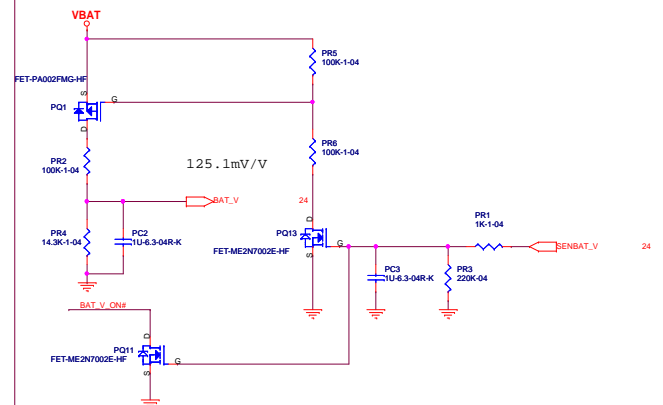

Charge / Discharge Detect

CHG_I should > 0.6V

Fast-charge-EN	CHG_I	Ich
H	3V	2.5A
H	1.8V	2A
H	0.6V	1.5A
L	2.4V	1A
L	1.2V	0.5A
L	0.6V	0.25A
L	0.3V	0.125A

CHG ON		CHG V	
L	CHARGER ON	H(2.5V)	16.8V (4CELL)
H	CHARGER OFF	L(0.6V)	12.6V (3CELL)

ADAPTOR_I	
1A	0.6V
1.5A	0.9V
2A	1.2V
2.5A	1.5V
3A	1.8V
3.5A	2.1V

Iad_max=Iad*Rad*60

Charge / Discharge Detect

Op-amp circuit: **OP4A LM358DR-SEMI**

VADAP=20V, Vm=2.0104V
VADAP=19V, Vm=1.914V

Power_P-State

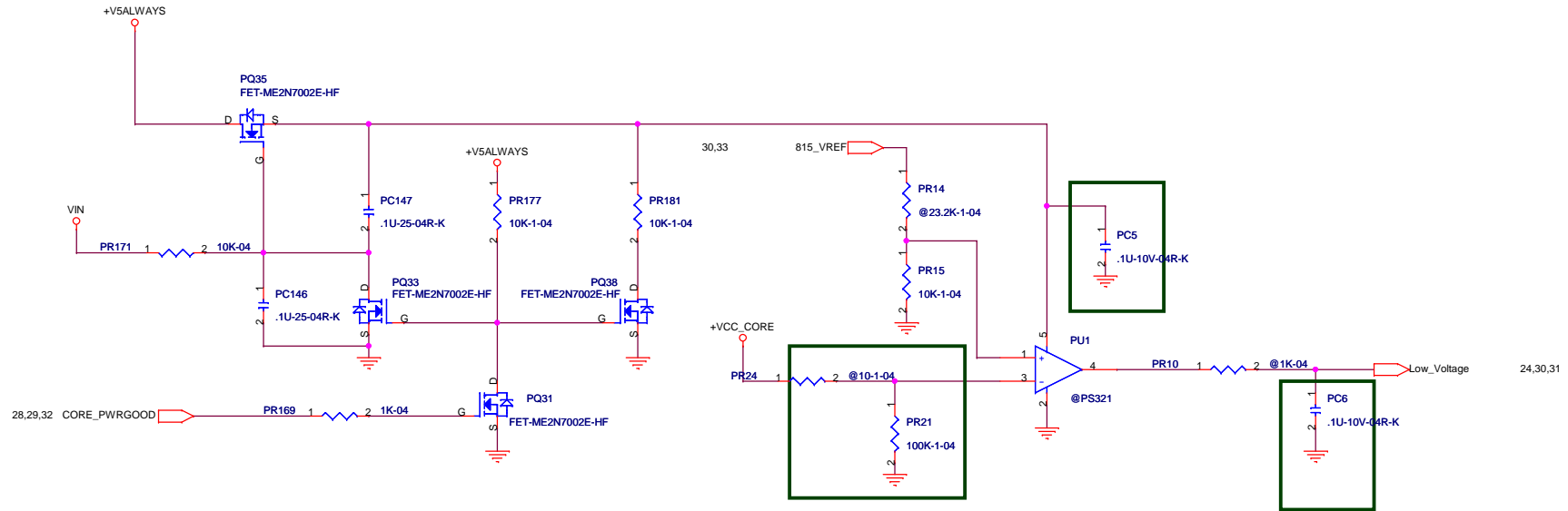

ELITEGROUP

Project : ES10ISx

Size	Document Number	Rev
	Power_P-State	A

Date: Sunday, February 13, 2011 Sheet 34 of 34